

STAUFF



Hydraulic Accessories

Local solutions for
individual customers
worldwide

STAUFF Hydraulic Accessories		Page
Level Gauges	SNA	4
Level Gauges	SNK	5
Thermo Switches	TS (for SNA and SNK)	6
Level-Temperature Switches	SLTS	7
Throttle and Flow Control Valves	DV/DRV (In-line mounting)	8
Throttle and Flow Control Valves	DVP/DRVP (Manifold mounting)	9
Throttle Valves	DVE (Cartridge assembly)	10
Flow Curves	DV/DRV - DVP/DRVP - DVE	11
Check Valves	RV (In-line mounting)	12
Plastic Filler Breathers	SPB	13-15
Plastic Filler Breathers	SPBN (Narrow Version)	16-17
Metal Filler Breathers		18-21
	SMBB (Bayonet style)/	
	SMBT (Screw-in style)/	
	SMBP (Push-on style)	
Angled side Mounting Brackets	SMBB-ASMB	22
Lockable Metal Filler Breathers	SMBL	23
Plastic Filler Breather	SES	24
Giant Air Breathers	SGB	25
Desiccant Air Breathers	SDB	26-27
Inclusive accessories: adaptor plates (AP), contamination indicator (FM), Drying agent refilling material (RD); replacement air filter inserts (SGB)		
Suction Strainers	SUS	28
Diffusers	SRV	29
Flow Indicators	SDM / SDM K	30-31
Pressure Gauges	SPG	32-33
Gauge Isolator Valves (Single/Multi Station)	SWS	34
Return Line Bushings	SRF	35

In the past you found information about our Spin-on-filters product range here.
This information now has been summarized in our new catalogue "Spin-on-filters", please contact STAUFF or your local distributor for your personal copy.



Area of Application:

Visual fluid level indication in hydraulic reservoirs

Characteristics:

- suitable for hydraulic oil HL and HLP
- option available with dial thermometer with probe or thermo switch (Page 6)
- UV-resistant

Please consult our office before using SNA with fluids such as biological oils, diesel fluids or gasoline. Special requirements (specific chemical resistance, particular UV-stability or special sizes) on request.

Technical Data:

Temperature range: -30°C ... +80°C
 Calibration of capillary tube thermometer:
 SNA 076 +20°C ... +80°C
 SNA 127/176/254/305 -10°C ... +80°C
 Calibration of dial thermometer with probe:
 0°C ... +100°C
 Tank pressure: 1 bar max
 Recommended tightening torque: 8 Nm

Materials:

Housing: St 12 (black epoxy)
 Plugs, Sight tube: PA
 Scale Plates: PVC

Design of scale plates

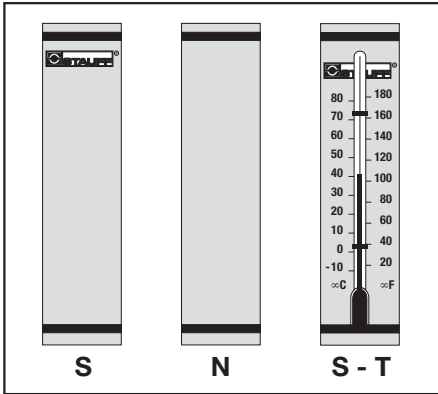

Dimensions

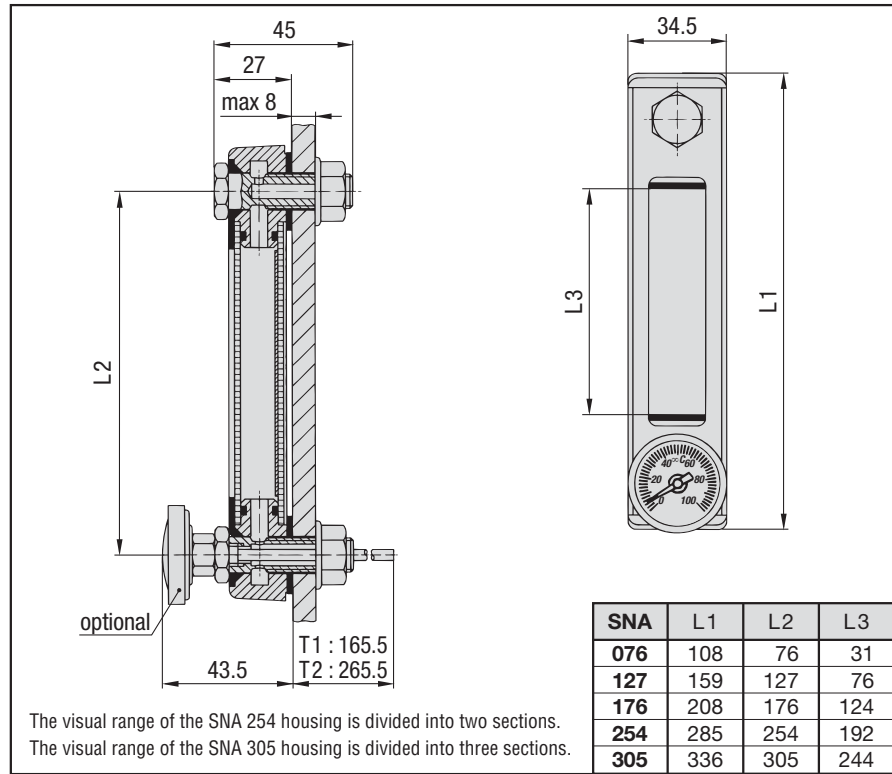

Ordering Code

SNA 127 B - S - O - 12 - O - 60

Type	SNA										
Series	<table border="1"> <tr><td>076</td><td>SNA 076</td></tr> <tr><td>127</td><td>SNA 127</td></tr> <tr><td>176</td><td>SNA 176</td></tr> <tr><td>254</td><td>SNA 254</td></tr> <tr><td>305</td><td>SNA 305</td></tr> </table>	076	SNA 076	127	SNA 127	176	SNA 176	254	SNA 254	305	SNA 305
076	SNA 076										
127	SNA 127										
176	SNA 176										
254	SNA 254										
305	SNA 305										
Seal material	<table border="1"> <tr><td>B</td><td>NBR (standard)</td></tr> <tr><td>V</td><td>FPM</td></tr> </table>	B	NBR (standard)	V	FPM						
B	NBR (standard)										
V	FPM										
Design of scale plate	<table border="1"> <tr><td>S</td><td>with STAUFF-Logo</td></tr> <tr><td>N</td><td>neutral</td></tr> <tr><td>X</td><td>Special executions</td></tr> </table>	S	with STAUFF-Logo	N	neutral	X	Special executions				
S	with STAUFF-Logo										
N	neutral										
X	Special executions										
Switching Temperature	<table border="1"> <tr><td>60</td><td>60°C/140°F</td></tr> <tr><td>70</td><td>70°C/150°C</td></tr> <tr><td>80</td><td>80°C/176°F</td></tr> </table>	60	60°C/140°F	70	70°C/150°C	80	80°C/176°F				
60	60°C/140°F										
70	70°C/150°C										
80	80°C/176°F										
Thermo Switch TS-SNA/SNK	<p>for size M12 only not in conjunction with thermometer T1 and T2</p> <table border="1"> <tr><td>(none)</td><td>without thermo switch</td></tr> <tr><td>O</td><td>Break Contact (n/c), standard plug</td></tr> <tr><td>OD</td><td>Break Contact (n/c), desina plug</td></tr> </table>	(none)	without thermo switch	O	Break Contact (n/c), standard plug	OD	Break Contact (n/c), desina plug				
(none)	without thermo switch										
O	Break Contact (n/c), standard plug										
OD	Break Contact (n/c), desina plug										
Banjo bolt	<table border="1"> <tr><td>12</td><td>M12 (standard)</td></tr> <tr><td>10</td><td>M10</td></tr> </table>	12	M12 (standard)	10	M10						
12	M12 (standard)										
10	M10										
Thermometer	<p>Dial thermometer with probe T1/T2 for size M12 only</p> <table border="1"> <tr><td>O</td><td>without thermometer</td></tr> <tr><td>T</td><td>Capillary tube thermometer on scale plate</td></tr> <tr><td>T1</td><td>Dial thermometer with 200 mm probe</td></tr> <tr><td>T2</td><td>Dial thermometer with 300 mm probe</td></tr> </table>	O	without thermometer	T	Capillary tube thermometer on scale plate	T1	Dial thermometer with 200 mm probe	T2	Dial thermometer with 300 mm probe		
O	without thermometer										
T	Capillary tube thermometer on scale plate										
T1	Dial thermometer with 200 mm probe										
T2	Dial thermometer with 300 mm probe										

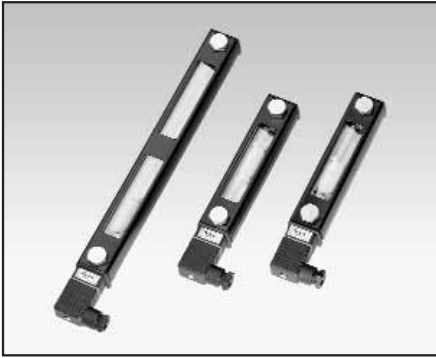

Area of Application:

Visual / electrical fluid level indication in hydraulic reservoirs

Characteristics:

- suitable for hydraulic oil HL and HLP
- option available with dial thermometer with probe or thermo switch (Page 6)
- UV-resistant
- available either as a break contact or make contact
- with plug according to DIN EN 175301-803-B/ISO6952 (industry standard) or with plug according to IEC 61076-2-101 M12 (type CD and OD)

Please consult our office before using SNA with fluids such as biological oils, diesel fluids or gasoline. Special requirements (specific chemical resistance, particular UV-stability or special sizes) on request.

Technical Data:

Temperature range: $-30^{\circ}\text{C} \dots +80^{\circ}\text{C}$
 Calibration of dial thermometer with probe:
 $0^{\circ}\text{C} \dots +100^{\circ}\text{C}$
 Tank pressure: 1 bar max
 Recommended tightening torque: 8 Nm
 Please allow a minimum spacing of 10 mm between other components.

Materials:

Housing: AL (plastic coated)
 Plugs, Sight tube: PA
 Float: PA

Electrical Connections and Functions

Contact load:
 max 10 W (Type C)
 max 5 W (Type O)

Bias-reducing Potential:
 50 V AC/DC

Current contact:
 max 0.25 A (both types)

Type C and O:
 connection 3
 not engaged

Type CD and OD:
 connection 2
 not engaged

View A

Dimensions

standard plug type C or O according to DIN EN 175301-803-B/ISO6952 (industry standard)

M 12 plug, A coded according to IEC 61076 type CD or OD

SNK	L1		L2
	Typ C+O	Typ CD+OD	
127	205	197	127
176	254	246	176
254	332	324	254
305	383	373	305

The visual range of the SNK 254 housing is divided into two sections.
 The visual range of the SNK 305 housing is divided into three sections.

Ordering Code

When assembling the electrical contacts the orientation of the electrical switch (right or left hand side) for type C and O can be chosen according to the requirements. For type CD and OD the orientation is set to right hand side. Other requirements on request.

SNK 127 V - C - O - 12 - O - 60

Switching Temperature	
60	60°C/140°F
70	70°C/150°C
80	80°C/176°F

Type	SNK
-------------	-----

Series	127 SNK 127
	176 SNK 176
	254 SNK 254
	305 SNK 305

Seal material	V FPM (standard)
----------------------	------------------

Electrical function	C Make contact, closes at minimum level (n/o), standard plug
	O Break contact, opens at minimum level (c/o), standard plug
	CD Make contact, closes at minimum level (n/o), M12 plug
	OD Break contact, opens at minimum level (c/o), M12 plug

Thermo Switch TS-SNA/SNK	for size M12 only not in conjunction with thermometer T1 and T2
(none)	without thermo switch
O	Break Contact (n/c), standard plug
OD	Break Contact (n/c), M12 plug

Banjo bolt	12 M12 (standard)
	10 M10

Thermometer	Dial thermometer with probe T1/T2 for size M12 only
O	without thermometer
T1	Dial thermometer with 200 mm probe
T2	Dial thermometer with 300 mm probe

Tel: +44 (0)191 549 7335 Fax: +44 (0)191 516 0004 Email: hos@hos.co.uk Website: www.hos.co.uk

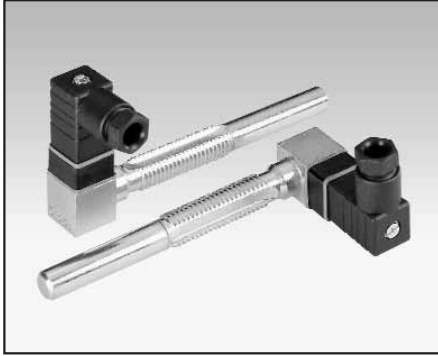

Area of Application: Oil temperature indication in conjunction with STAUFF level gauges SNA and SNK

Characteristics/Materials:

- available with 60°C, 70°C or 80°C switching temperature
- Activation takes place when the respective switching temperature is exceeded.
- Electrical function: break contact
- With plug according to DIN EN 175301-803-B/ISO6952 (industry standard) or with plug according to IEC 61076 - 2-101 M12 (type OD)
- Steel parts made out of steel (1.0718)
- Plastic parts made out of glass fibre reinforced Polyamide

Thermo switches are available for the standard mounting size M12 only.

Dimensions

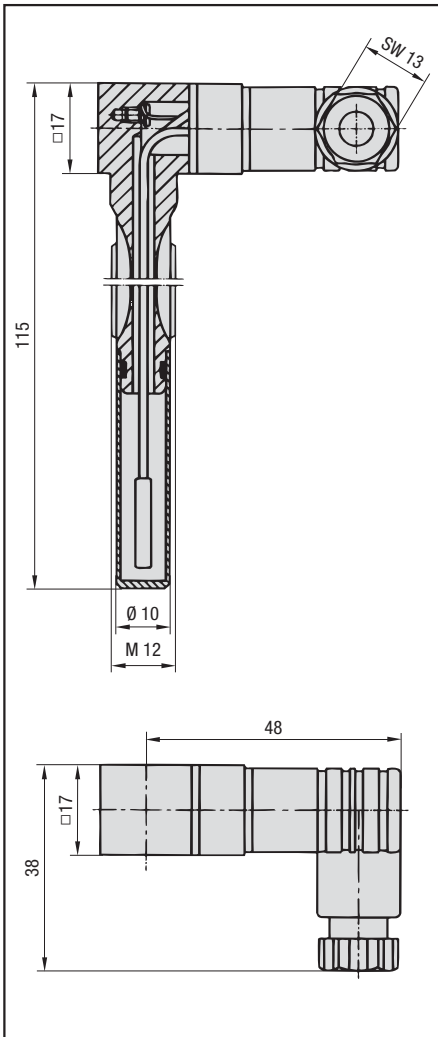

Technical Data

Switching temperature: see ordering code
 Hysteresis: 20° C
 Switching temperature tolerance: ± 5° C.

Alternating current

- max voltage 250 V
- max current at 10.000 operations
 - 2.5 A at cos φ = 1.0
 - 1.6 A at cos φ = 0.6
- max current at 100.000 operations
 - 0.5 A at cos φ = 1.0
 - ≈ 0.25 A at cos φ = 0.6
- min voltage 50 mA

Direct current

- max voltage 42 V
- max current at 10.000 circuits 1 A

Example of application

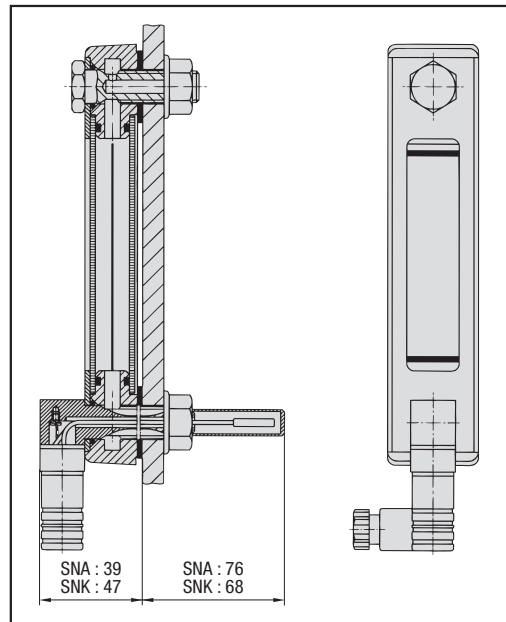

Option plug

standard plug type O according to DIN EN 175301-803-B/ISO6952 (industry standard)

M 12 plug, A coded according to IEC 61076 type OD

see page 5 for electrical connections and functions

Ordering Code and Switching temperatures

TS - SNA / SNK - O - 60

Type	TS Thermo Switch
Series	SNA / SNK
Switching temperature	60 60°C / 140°F 70 70°C / 158°F 80 80°C / 176°F
Electrical function	O Break Contact (n/c), standard plug OD Break Contact (n/c), M12 plug

Thermo switches can be ordered both as a single component and in combination with STAUFF level gauges SNA and SNK. See pages 4 and 5.



Area of Application:

Electrical level and temperature indication

Characteristics:

- suitable for mineral oil and HFC fluids, other fluids on request
- either 1 or 2 level contacts available
- 1 integrated temperature sensor
- standard electrical function:
 Level contacts: normally closed, opens with falling level
 Temperature contact: normally closed, opens with rising temperature

STAUFF Level-Temperature switches SLTS are available with other electrical functions on request.

Technical Data

Stem:	Brass
Float/Seal:	NBR
max operating temperature:	80°C
max operating voltage:	see ordering code
max current (level contact):	0.5 A
max current (temperature contact):	2.0 A
contact load level contact:	10 VA
system of protection:	IP65
Hysteresis:	12°C

Level contact positions (L, H) are set as given in the chart. They can be adjusted individually later on.

Please consider a minimum distance of 40 mm between the switching points.

Wiring Scheme for type 2LH

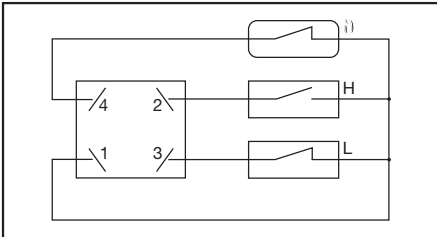

Wiring Scheme for type 1L or 1H

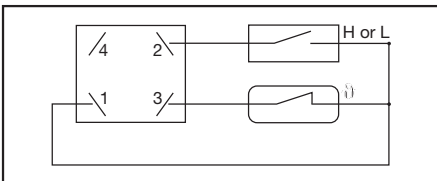

Dimensions

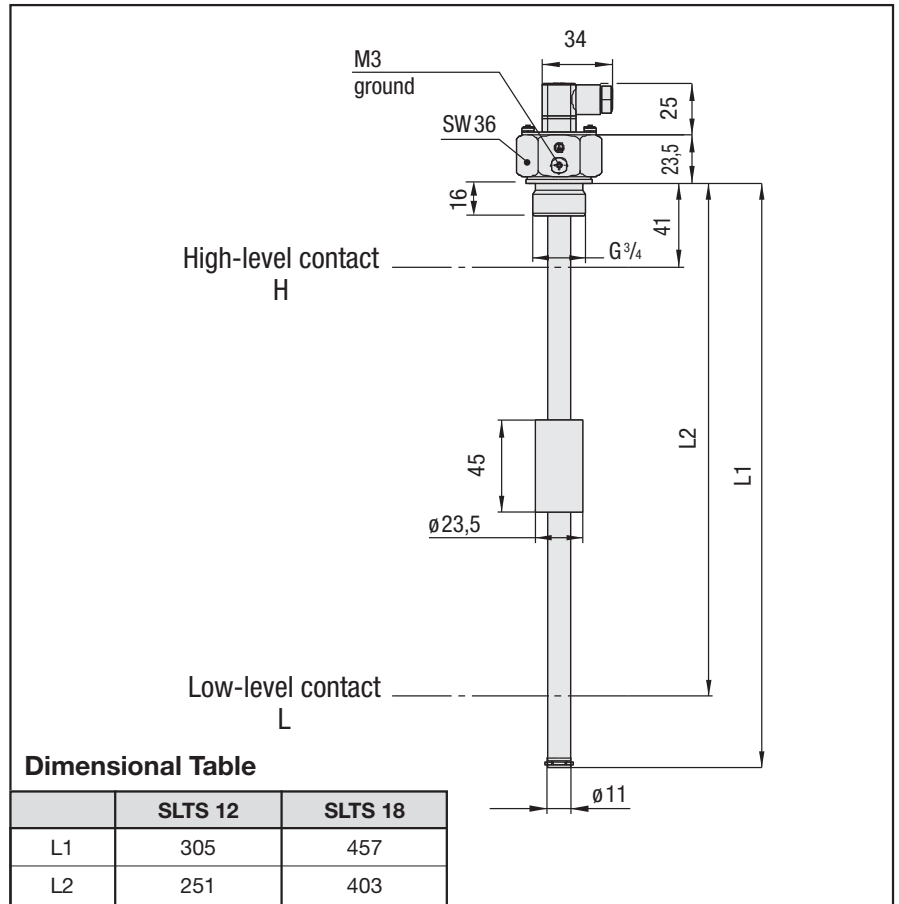

Dimensional Table

	SLTS 12	SLTS 18
L1	305	457
L2	251	403

Ordering Code

SLTS 12 - 140 - 2LH - B12 - G048

<table border="1" style="width: 100%; border-collapse: collapse;"> <tr> <th colspan="2">Type</th> </tr> <tr> <td style="width: 10%;">SLTS</td> <td>Level-temperature switch</td> </tr> </table> <table border="1" style="width: 100%; border-collapse: collapse;"> <tr> <th colspan="2">Stem Length</th> </tr> <tr> <td style="width: 10%;">12</td> <td>305 mm</td> </tr> <tr> <td>18</td> <td>457 mm</td> </tr> </table> <table border="1" style="width: 100%; border-collapse: collapse;"> <tr> <th colspan="2">Switching temperature</th> </tr> <tr> <td style="width: 10%;">140</td> <td>60°C / 140°F</td> </tr> <tr> <td>158</td> <td>70°C / 158°F</td> </tr> <tr> <td>O</td> <td>without temperature switch</td> </tr> </table>	Type		SLTS	Level-temperature switch	Stem Length		12	305 mm	18	457 mm	Switching temperature		140	60°C / 140°F	158	70°C / 158°F	O	without temperature switch	<table border="1" style="width: 100%; border-collapse: collapse;"> <tr> <th colspan="2">Voltage (Volt AC/DC)</th> </tr> <tr> <td style="width: 10%;">G048</td> <td>48 Volt max (standard)</td> </tr> <tr> <td>G115</td> <td>115 Volt max (for thread N16 only)</td> </tr> </table> <table border="1" style="width: 100%; border-collapse: collapse;"> <tr> <th colspan="2">Thread</th> </tr> <tr> <td style="width: 10%;">B12</td> <td>G³/₄ (standard)</td> </tr> <tr> <td>N16</td> <td>1 NPT (only on request)</td> </tr> </table>	Voltage (Volt AC/DC)		G048	48 Volt max (standard)	G115	115 Volt max (for thread N16 only)	Thread		B12	G ³ / ₄ (standard)	N16	1 NPT (only on request)	<table border="1" style="width: 100%; border-collapse: collapse;"> <tr> <th colspan="2">Number of level switches</th> </tr> <tr> <td style="width: 10%;">1</td> <td>1 level switch (L, H)*</td> </tr> <tr> <td>2</td> <td>2 level switch (LH)</td> </tr> </table> <p style="font-size: small;">* please indicate level position(s): L = low, H = high</p>	Number of level switches		1	1 level switch (L, H)*	2	2 level switch (LH)
Type																																						
SLTS	Level-temperature switch																																					
Stem Length																																						
12	305 mm																																					
18	457 mm																																					
Switching temperature																																						
140	60°C / 140°F																																					
158	70°C / 158°F																																					
O	without temperature switch																																					
Voltage (Volt AC/DC)																																						
G048	48 Volt max (standard)																																					
G115	115 Volt max (for thread N16 only)																																					
Thread																																						
B12	G ³ / ₄ (standard)																																					
N16	1 NPT (only on request)																																					
Number of level switches																																						
1	1 level switch (L, H)*																																					
2	2 level switch (LH)																																					



Area of Application: Fluid control and flow shut-off

- DV: in both directions
- DRV: in direction A-B (free flow in reverse direction)

Characteristics/Materials:

- designed for in-line mounting
- suitable for mineral oil
- Nuts for panel-mounting are available on request
- Housing: Steel (1.0715), zinc-plated (Fe/Zn 8 C)
- Turning knob: Polyamide

Please consult our office before using with other fluids, or for special stainless steel material.

Technical Data:

max Working Pressure p_N : 350 bar
 Temperature t_{max} : 100°C
 Opening Pressure DRV:
 0.5 bar (4.5 bar on request)

Dimensions

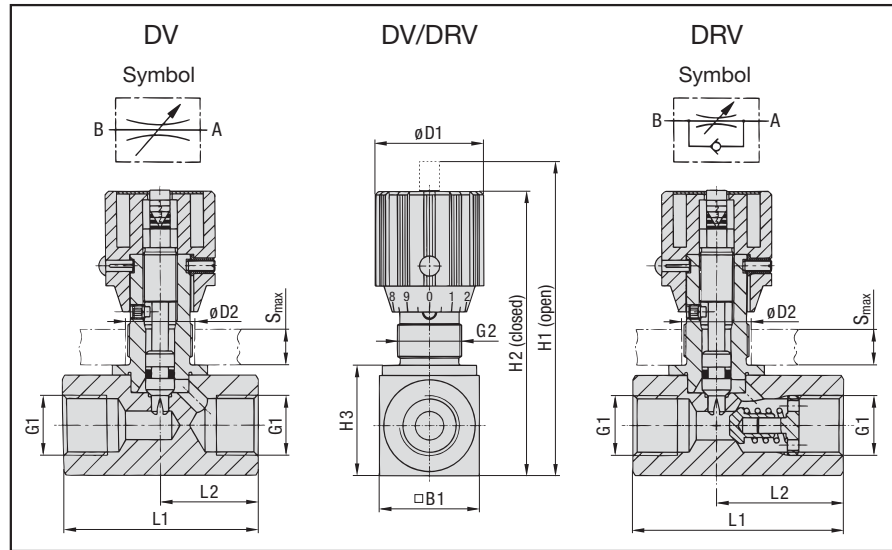

Dimensional Table

Nominal Size DN	G1		DV/DRV								DV			DRV		
	BSP	NPT	G2	H1	H2	H3	B1	D1	D2	S _{max}	L1	L2	wt. (kg)	L1	L2	wt. (kg)
06	G 1/8	1/8 NPT	PG 7	68	63	18	16	24	13	3	38	19	0.12	45	26	0.13
08	G 1/4	1/4 NPT	PG 11	83.5	77.5	27	25	29	19	7	48	24	0.25	55	33.5	0.3
10	G 3/8	3/8 NPT	PG 11	90	83	32	30	29	19	7	58	29	0.4	65	41	0.45
12	G 1/2	1/2 NPT	PG 16	109.5	99.5	38.5	35	38	23	7	68	34	0.7	73	44	0.8
16	G 3/4	3/4 NPT	PG 16	128.5	118.5	48.5	45	38	23	7	78	39	1.2	88	57	1.3
20	G 1	1 NPT	PG 29	174	157	55	50	55	38	11	108	54	2.1	127	77	2.4
25	G 1 1/4	1 1/4 NPT	PG 29	184	167	65	60	55	38	11	108	54	2.8	143	93	3.5
30	G 1 1/2	1 1/2 NPT	PG 29	194	177	75	70	55	38	11	108	54	3.5	143	91	4.6
40	G 2	2 NPT	PG 29	214	197	95	90	55	38	11	-	-	-	165	111	7.7

Ordering Code

DV - 25 - P - B - SS

<p>Type (in-line mounting)</p> <table border="1"> <tr> <td>DV</td> <td>Throttle and shut-off valve</td> </tr> <tr> <td>DRV</td> <td>Flow control valve</td> </tr> </table> <p>Nominal size DN</p> <table border="1"> <tr> <td>06</td> <td>08</td> <td>10</td> <td>12</td> <td>16</td> <td>20</td> <td>25</td> <td>30</td> <td>40 (only DRV)</td> </tr> </table> <p>Seal material</p> <table border="1"> <tr> <td>P</td> <td>NBR (standard)</td> </tr> <tr> <td>V</td> <td>FPM</td> </tr> <tr> <td>E</td> <td>EPDM</td> </tr> </table>	DV	Throttle and shut-off valve	DRV	Flow control valve	06	08	10	12	16	20	25	30	40 (only DRV)	P	NBR (standard)	V	FPM	E	EPDM	<p>Housing / spindle material</p> <table border="1"> <tr> <td>(none)</td> <td>Steel (standard)</td> </tr> <tr> <td>SS</td> <td>Stainless steel (1.4571)</td> </tr> </table> <p>Thread form</p> <table border="1"> <tr> <td>B</td> <td>BSP (standard)</td> </tr> <tr> <td>N</td> <td>NPT (only on request)</td> </tr> </table>	(none)	Steel (standard)	SS	Stainless steel (1.4571)	B	BSP (standard)	N	NPT (only on request)
DV	Throttle and shut-off valve																											
DRV	Flow control valve																											
06	08	10	12	16	20	25	30	40 (only DRV)																				
P	NBR (standard)																											
V	FPM																											
E	EPDM																											
(none)	Steel (standard)																											
SS	Stainless steel (1.4571)																											
B	BSP (standard)																											
N	NPT (only on request)																											



Area of Application: Fluid control and flow shut-off

- DVP: in both directions
- DRVP: in direction A-B (free flow in reverse direction)

Characteristics/Materials:

- designed for manifold mounting
- suitable for mineral oils
- Housing: Steel (1.0715), zinc-plated (Fe/Zn 8 C)
- Turning knob: Polyamide

Please consult our office before using with other fluids, or for special stainless steel material.

Technical Data:

max Working Pressure p_N : 350 bar
 Temperature t_{max} : 100°C
 Opening Pressure DRVP:
 0.5 bar (4.5 bar on request)

Dimensions

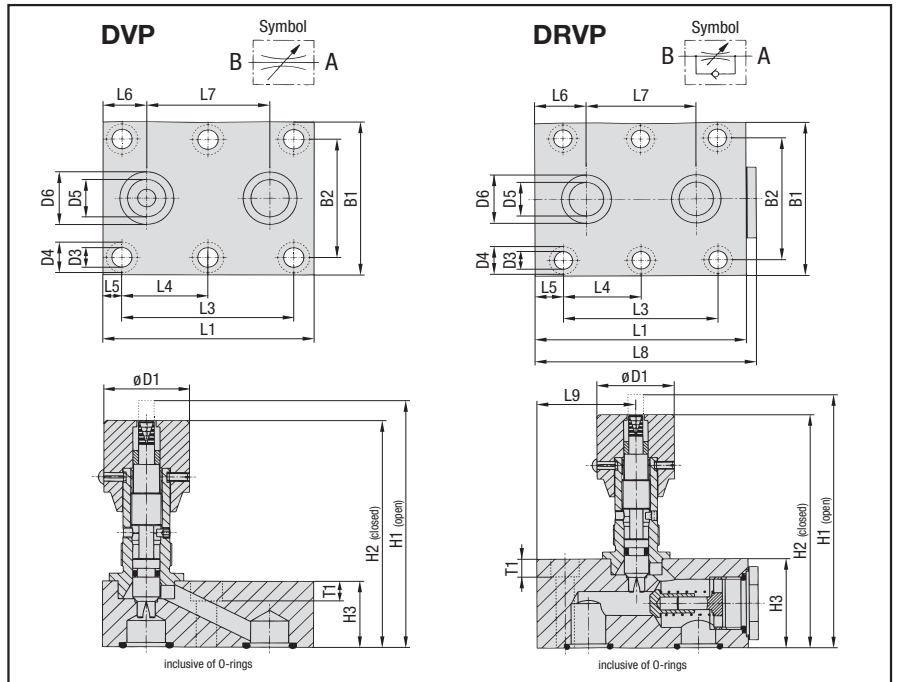

G2, D2 und S_{max}
 see Dimensional Table DV/DRV (page 8)

Dimensional Table

Nom. Size DN	DVP and DRVP													DVP							DRVP							
	D1	D3	D4	D5	D6	L3	L4	L7	B1	B2	T1	O-Ring	L1	L5	L6	H1	H2	H3	wt. (kg)	L1	L5	L6	L8	L9	H1	H2	H3	wt. (kg)
06	24	6.6	11	5	9.8	19	-	16	41.5	28.5	7	6.75x1.78	35	8	9.5	68	63	16	0.2	41.5	6.4	8	43	13.5	68	63	16	0.26
08	29	6.6	11	7	12.4	35	-	25.5	46	33.5	7	8.5x2	47.5	6.5	11	79	72	20	0.4	63.5	14.2	16.7	65	31	79	72	20	0.5
10	29	6.6	11	10	15.7	33.5	-	25.5	51	38	7	12x2	51	8.5	12.7	84	78	25	0.6	70	18	22	73	29.5	84	78	25	0.8
12	38	6.6	11	13	18.7	38	-	30	57.5	44.5	7	15x2	75	18.5	22.5	100	89	25	1.0	80	21	25	84	36.5	107	96	32	1.2
16	38	8.5	13.5	17	23.9	76	38	54	70	54	9	19x2.5	93.5	8.5	19.5	113	103	30	1.5	104	14	25.4	108	49	128	118	45	2.5
20	55	8.5	13.5	22	30.5	95	47.5	57	76.5	60	9	25x3	111	8	27	169	152	45	3.4	127	16	35	131	49	174	157	50	3.9
25	55	11	18	28.5	37.5	120	60	79.5	100	76	11	32x3	143	11	32	169	152	45	5.15	165	15	35.6	169	77	179	162	55	6.7
30	55	14	20	35	43.5	143	71.5	95	115	92	13	38x3	171	15	39	174	157	50	7.5	186	15	38.8	190	85	199	182	75	11.0
40	55	14	20	47.5	57.5	133.5	67	89	140	111	13	52x3	-	-	-	-	-	-	-	192	15	40.5	196	64	224	207	100	18.8

Ordering Code

DVP - 25 - P - SS

Type (manifold mounting)		Housing/spindle material
DVP	Throttle and shut-off valve	(none) Steel (standard)
DRVP	Flow control valve	SS Stainless steel (1.4571)
Nominal size DN		Seal material
06 08 10 12 16 20 25 30 40 (only DRVP)		P NBR (standard)
		V FPM
		E EPDM



Area of Application:
Fluid control and flow shut-off

Characteristics/Materials:

- designed for direct installation into hydraulic control blocks
- suitable for mineral oils
- Housing: Steel (1.0715), zinc-plated (Fe/Zn 8 C)
- Standard thread form: BSP; NPT on request
- Turning knob: Polyamide

Please consult our office before using with other fluids, or for special stainless steel material and other thread forms.

Technical Data:

max Working Pressure p_N : 350 bar
Temperature t_{max} : 100°C

Dimensions

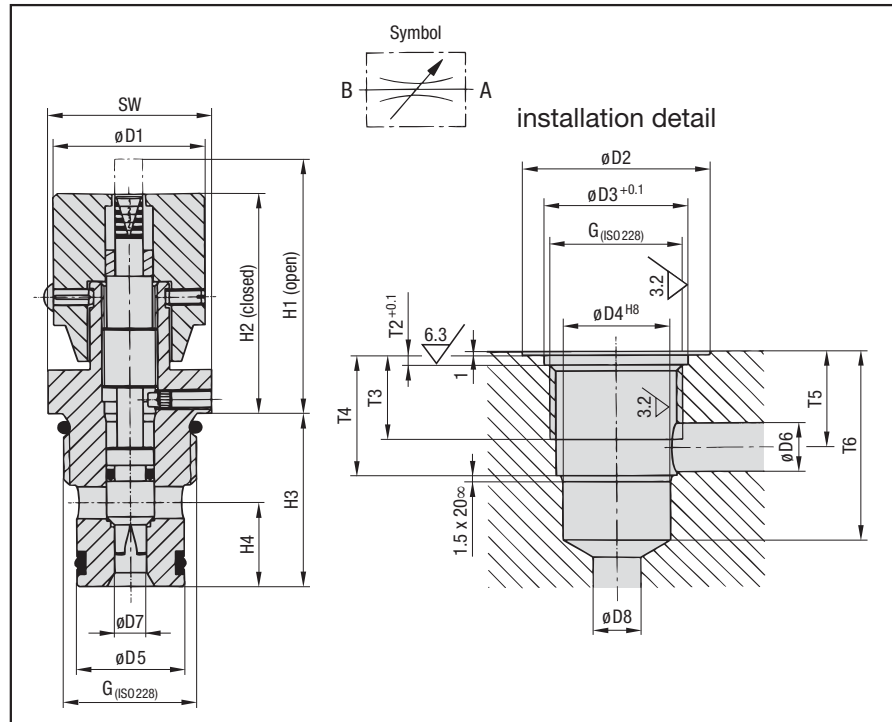

Dimensional Table

Nominal Size DN	G		H1	H2	H3	H4	D1	D2	D3	D4	D5	D6	D7	D8	SW	T2	T3	T4	T5	T6	Gew (kg)
	BSP	NPT																			
08	G 1/2	1/2 NPT	47	41	27.5	12	29	32	24	14	14	5	5	5	27	1.9	14	17.5	15	29	0.15
10	G 1/2	1/2 NPT	64	54	30.7	14.5	38	32	24	16	16	8	6	8	27	1.9	14	20.5	17	33	0.25
12	G 3/4	3/4 NPT	65	55	40	17.5	38	37	30	19	19	10	8	10	32	1.9	21	29	24	43	0.5
16	G 1	1 NPT	65	55	43.5	21.1	38	47	36	27	27	12	8	12	41	2.4	21	30	24	47	0.7

Ordering Code

DVE - 16 - P - B - SS

Type	Housing/spindle material
DVE Throttle valve for cartridge assembly	(none) Steel (standard) SS Stainless steel (1.4571)
Nominal size DN	Thread form
08 10 12 16	B BSP (standard) N NPT (only on request)
Seal material	
P NBR (standard) V FPM E EPDM	

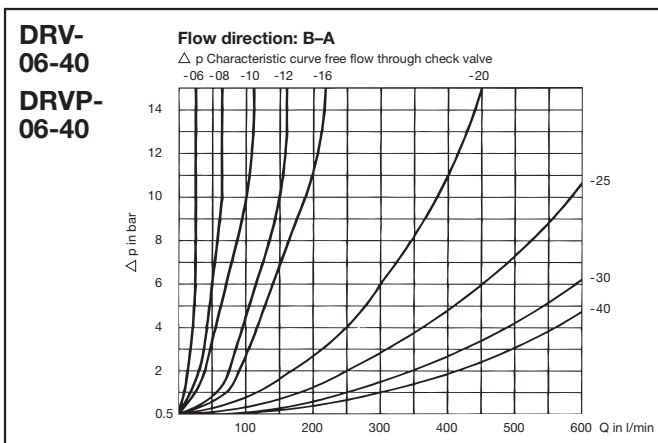
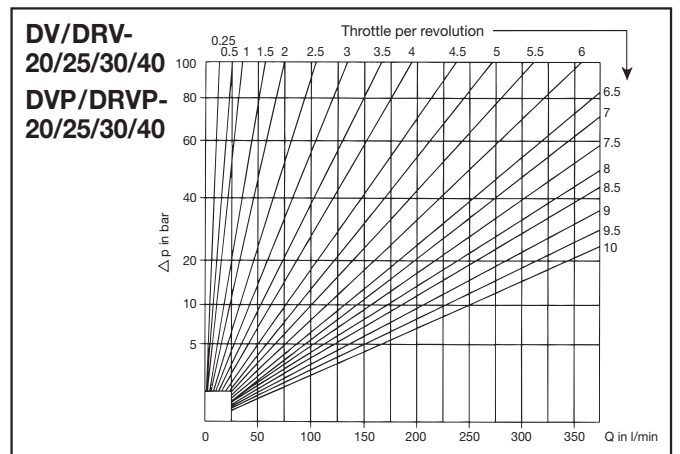
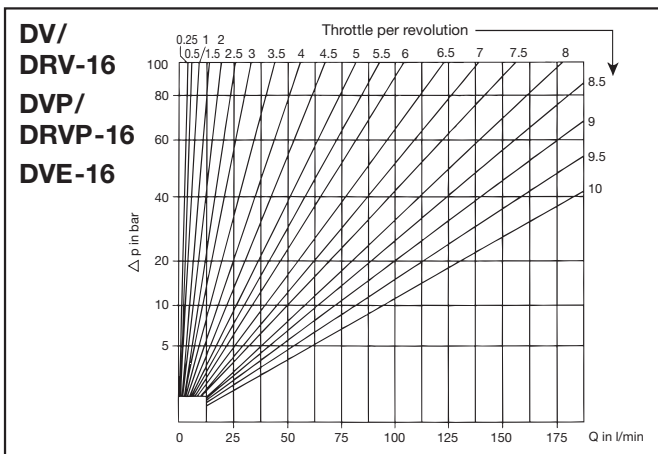
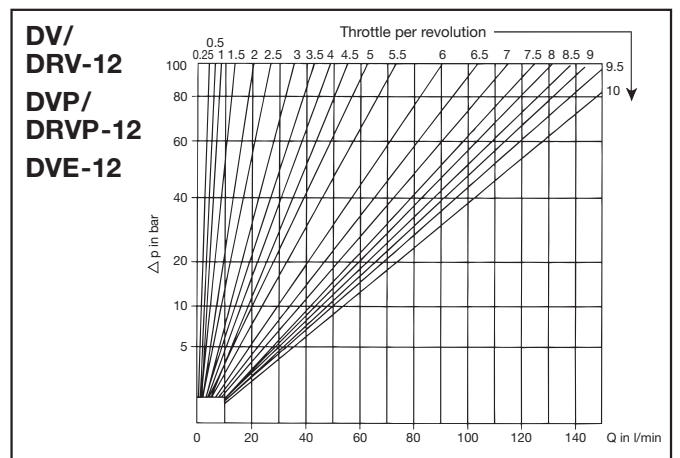
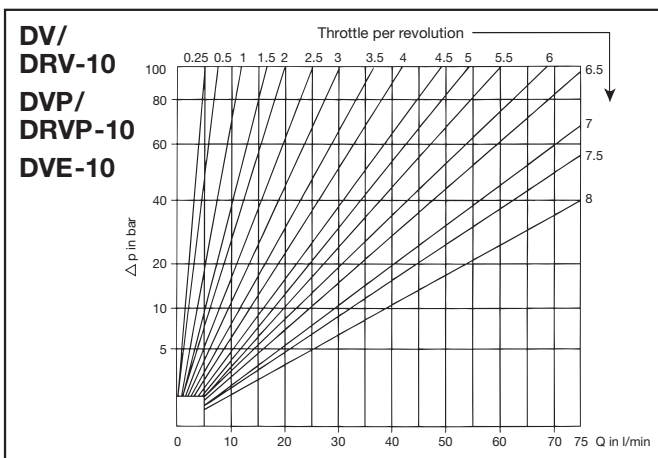
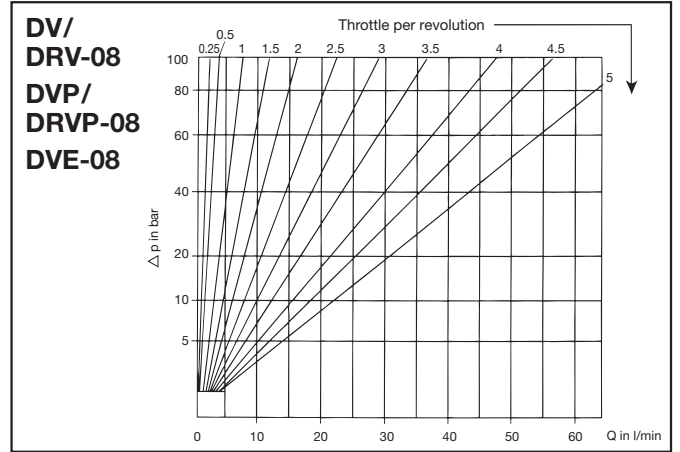
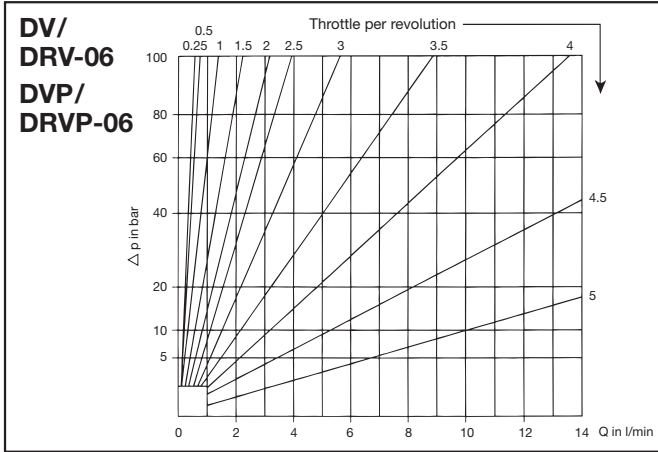

STAUFF throttle and flow control valves are designed to shut off and control the flow of liquid media. The flow rate is regulated on a direct reading device by turning the handle from completely closed to fully open and is set by screws.

The increase in flow is also indicated by a colour and number scale. This is revealed on a central spindle emerging from the turning during operation.

The values given refer to a viscosity of 35 cSt.



Area of Application:

Check valves allow a single-directional flow only.

Characteristics/Materials:

- designed for in-line mounting
- suitable for mineral oil
- Housing: Steel (1.0715), zinc-plated (Fe/Zn 8 C)
- Standard thread form: BSP; NPT on request
- metal-to-metal seals

Please consult our office before using with other fluids, or for special material and thread sizes.

Technical Data:

Temperature t_{max} : 100°C

Opening Pressure RV: 0.5 bar (4.5 bar on request)

Dimensions

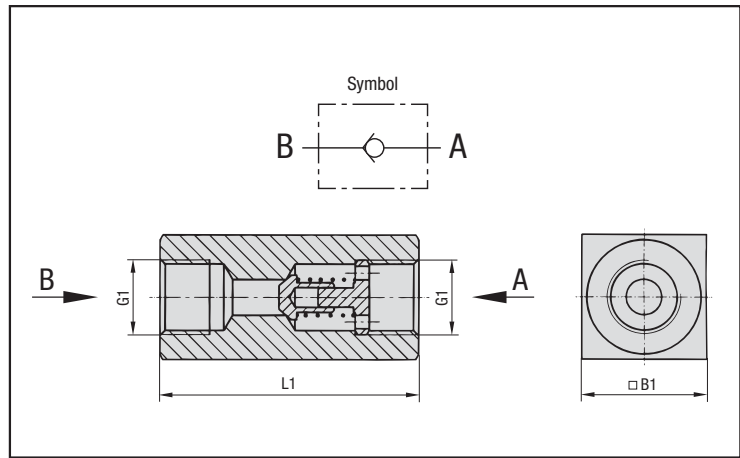
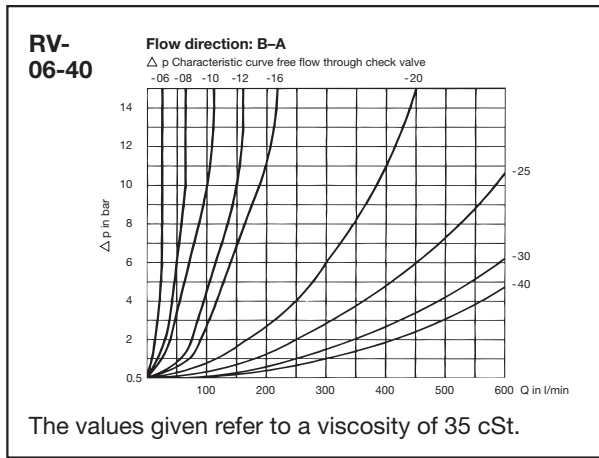

Dimensional Table

Nominal Size DN	p _N (bar)	G1		L1	B1	Weight (kg)
		BSP	NPT			
06	500	G 1/8	1/8 NPT	45	16	0.1
08	500	G 1/4	1/4 NPT	55	25	0.2
10	500	G 3/8	3/8 NPT	65	30	0.4
12	500	G 1/2	1/2 NPT	73	35	0.7
16	500	G 3/4	3/4 NPT	88	45	1.2
20	500	G 1	1 NPT	127	50	2.0
25	400	G 1 1/4	1 1/4 NPT	143	60	3.3
30	315	G 1 1/2	1 1/2 NPT	143	70	4.2
40	315	G 2	2 NPT	165	90	7.2

Ordering Code

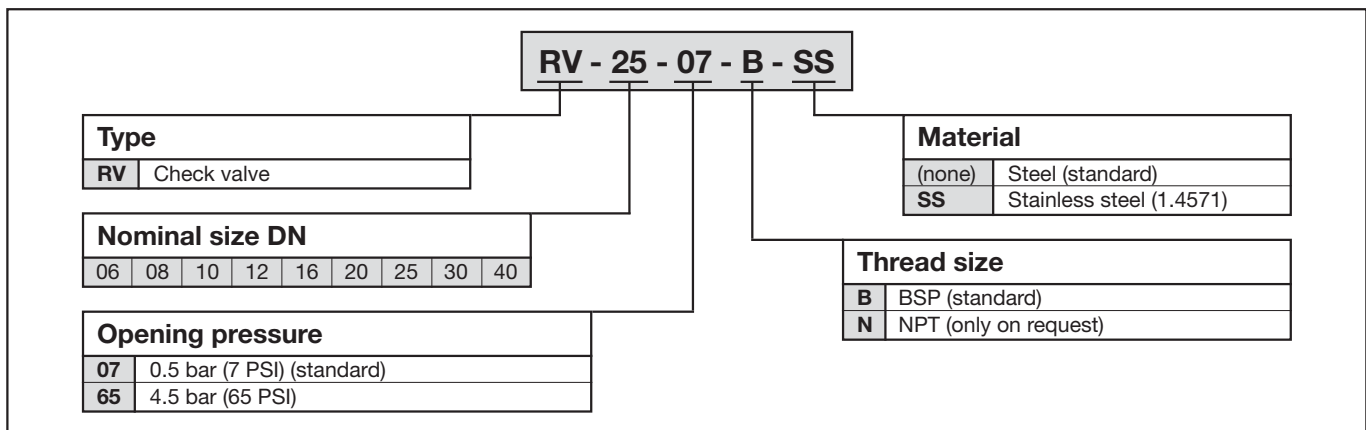



Area of Application:

Ventilation and tank filling

Characteristics/Materials:

- available as screw-in or bayonet version
- non-corrosive
- Temperature range: - 40°C ... + 120°C
- Materials: glassfibre reinforced PA, basket PP
- Seals: NBR, others on request
- Air filter insert: see order table page 15

Custom built combinations and special requirements available on request.

Dimensions and Styles – Screw-in versions (Breathers)

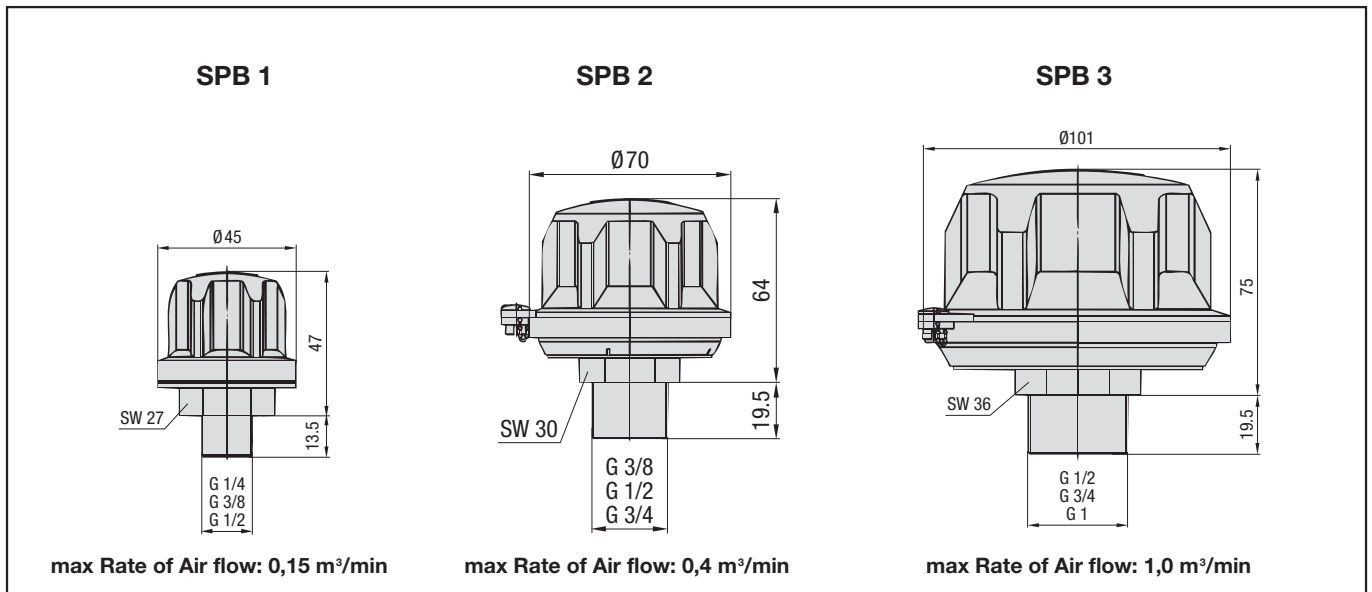

Dimensions and Styles – Bayonet version (Filler Breathers)

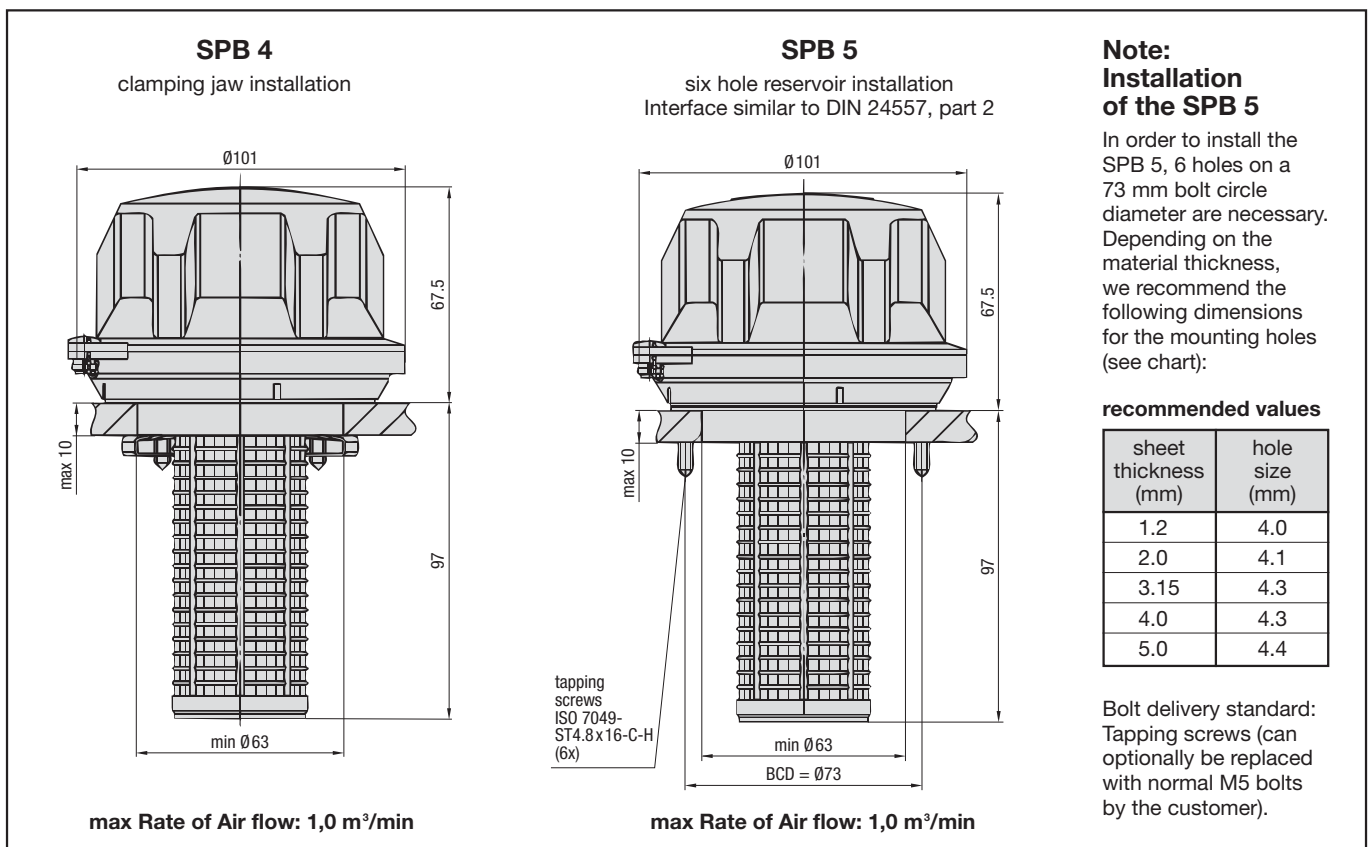

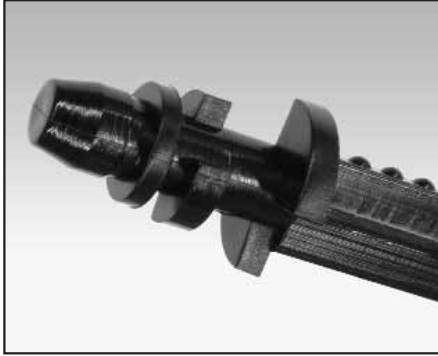

Breather options:

- Dipsticks (material PA)
- Pressurised versions (for SPB 2 up to SPB 5)
- Baskets (for SPB 4 and SPB 5)
- Thread form NPT (for SPB 1 up to SPB 3)

Special executions available on request.

Photo: integrated anti-splash feature

Dipsticks and Anti-splash feature

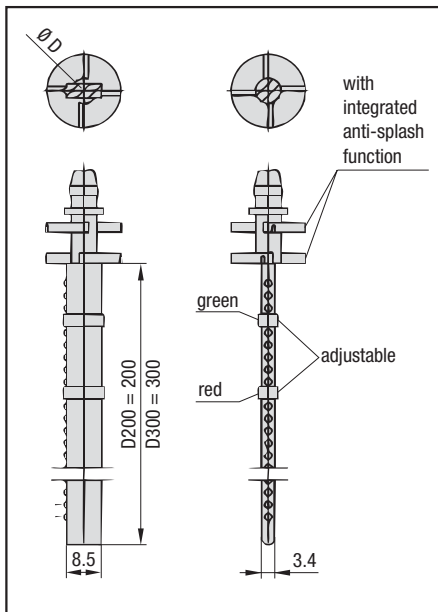

Adaptation form	for type	suitable dipstick	Dimension ØD
B04	SPB 1	n/a	–
B06	SPB 1 + 2	DS-1	10
B08	SPB 1 – 3	DS-2	14
B12	SPB 2 + 3	DS-3	18
B16	SPB 3	DS-3	18
S080	SPB 4 + 5	DS-3	18
S200	SPB 4 + 5	DS-3	18
X	SPB 4 + 5	DS-3	18

For all filler breathers SPB 1 up to SPB 5, dipsticks (material Polyamide) are available as an option. All these dipsticks have an integrated anti-splash function. This anti-splash feature protects the SPB from backspilling fluid and avoids an early air filter breakdown. For filler breathers without dipstick the anti-splash function is achieved by an integrated concave baffle. Because of its small size the anti-splash function for the size 1 can only be achieved in conjunction with a dipstick. Depending on the chosen filler breather (see table above), dipsticks are available in two standard lengths (200 mm and 300 mm). Smaller dipstick sizes can be achieved by simply cutting down its length on site, according to individual requirements.

Pressurised versions:

Optionally all filler breathers, except size 1, are available as pressurised breathers. In order to achieve an air flow, the tank pressure has to exceed the chosen pressure setting. This feature minimizes foaming and cavitation. Available pressure settings: 0.2 bar, 0.35 bar and 0.7 bar.

Baskets for SPB 4 and 5

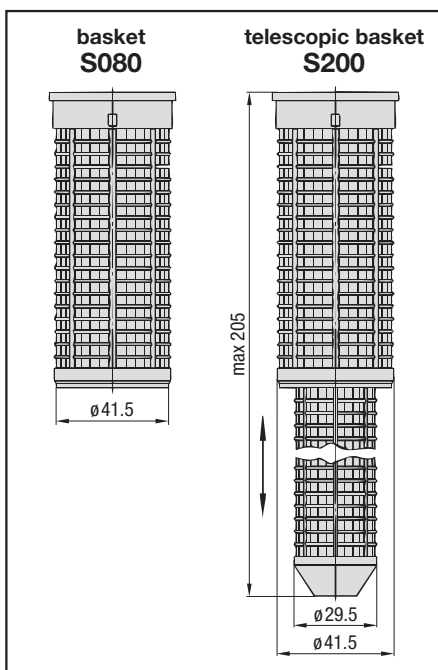

For the filler breathers SPB 4 and SPB 5, 80 mm and 200 mm baskets (material Polypropylene) are available as an option. All baskets have a reinforced 0.8 x 3.5 mm mesh. With the basket S080 and the telescopic basket S200, rough dirt particles are filtered out of the medium and a smooth flow into the tank is being ensured.

Ordering Code

SPB - S - 2 - 10 - B12 - A - D300

Typ		Dipstick option	
SPB	Plastic filler breather	(none)	without dipstick
		D200	dipstick 200 mm
		D300	dipstick 300 mm

Version (Pressurisation not available for SPB 1)		Anti-splash option	
S	without pressurisation (standard)	A	with anti-splash option (standard)
P1	pressurised at 0.20 bar	O	without anti-splash option
P2	pressurised at 0.35 bar		
P3	pressurised at 0.70 bar		

Group size			
size	version	cap diameter	max rate of air flow (m ³ /min)
1	screw-in version	45	0.15
2	screw-in version	70	0.4
3	screw-in version	101	1.0
4	single hole reservoir installation	101	1.0
5	six hole reservoir installation	101	1.0

Connection			
B04	G ¹ / ₄ (for SPB 1)		
B06	G ³ / ₈ (for SPB 1 + 2)		
B08	G ¹ / ₂ (for SPB 1 - 3)		
B12	G ³ / ₄ (for SPB 2 + 3)		
B16	G1 (for SPB 3)		
S080	basket (for SPB 4 + 5)		
S200	telescopic basket (for SPB 4 + 5)		
X	without basket (for SPB 4 + 5)		

Micron rating and Filter material			
code	foam (PUR)	code	Inorganic glassfiber (only SPB 3,4 and 5)
10	10 µm PUR (standard)	E03	3 µm inorganic glass fiber (pleated)
40	40 µm PUR (on request)		
		L10	10 µm filterpaper (pleated)

other micron ratings or filtermaterial on request

Airflow plastic filler breathers SPB 1 – 5

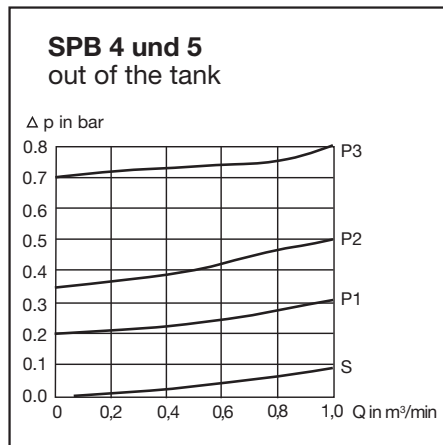
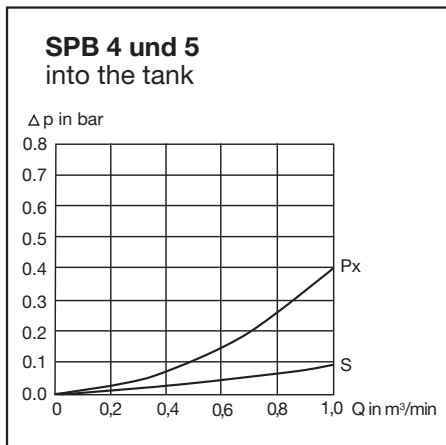
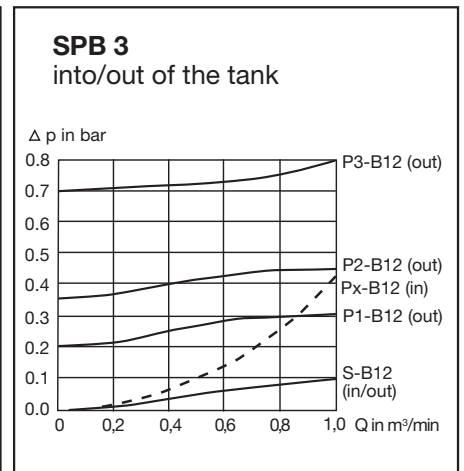
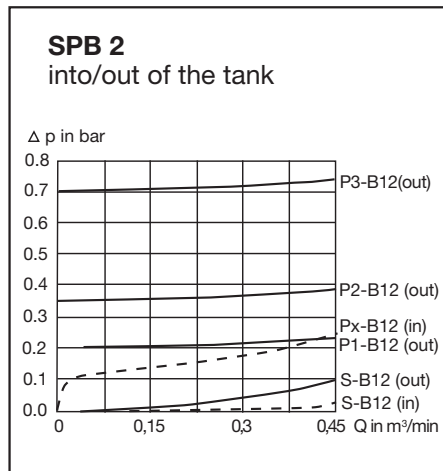
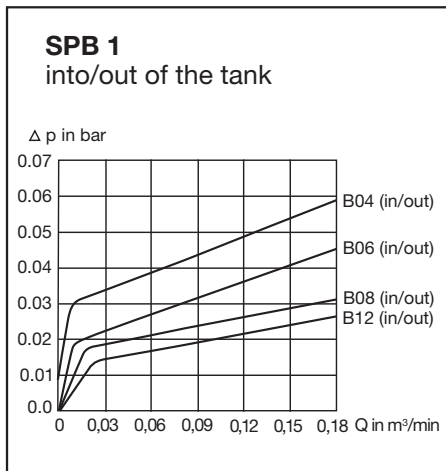



Area of Application:

Ventilation and tank filling

Characteristics/Materials:

- available as screw-in or bayonet version
- non-corrosive
- Temperature range: -40°C ... +120°C
- Materials: glassfibre reinforced PA
- Seals: NBR, others on request
- Air filter insert: see order table page 17

Options:

- Plastic dipsticks with integrated anti-splash function
- Metal basket (micron rating 800 µm)
- Thread style BSP and NPT available
- Pressurised at 0,20, 0,35 or 0,70 bar

Custom built combinations and special requirements available on request.

Dimensions and Styles

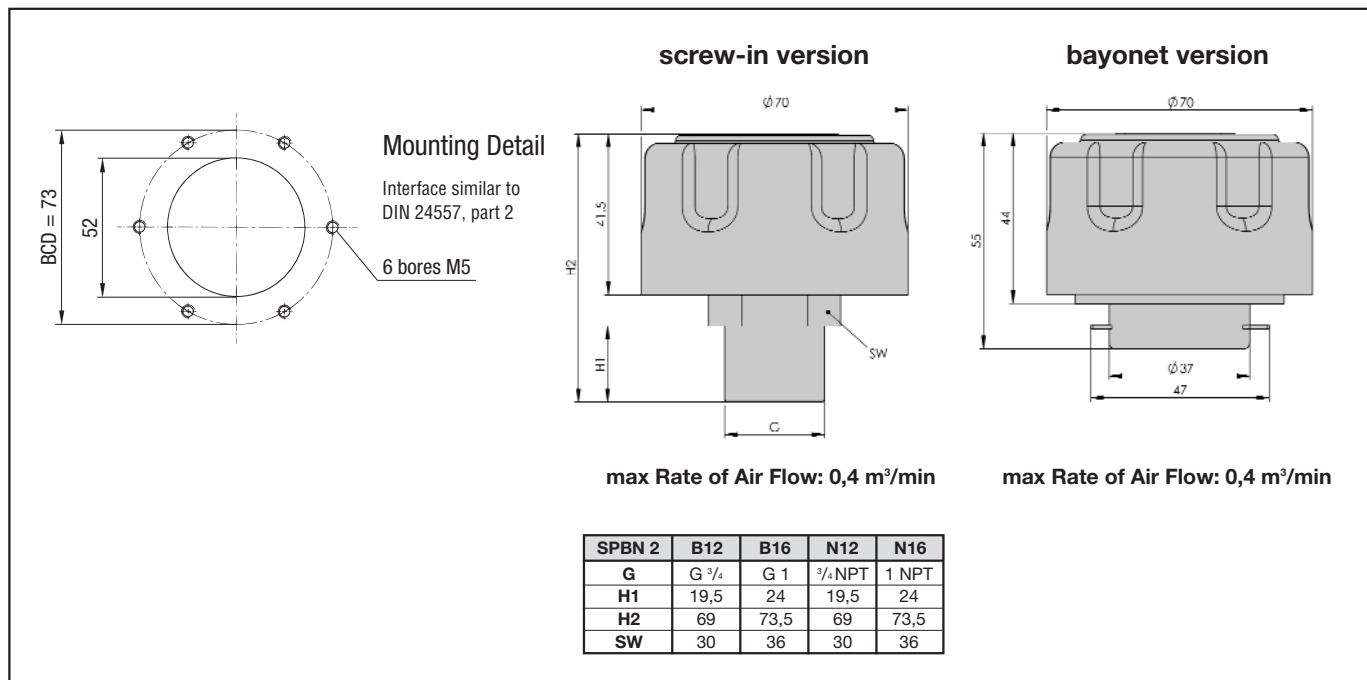

Accessories: Mounting Adapter for Metal Basket

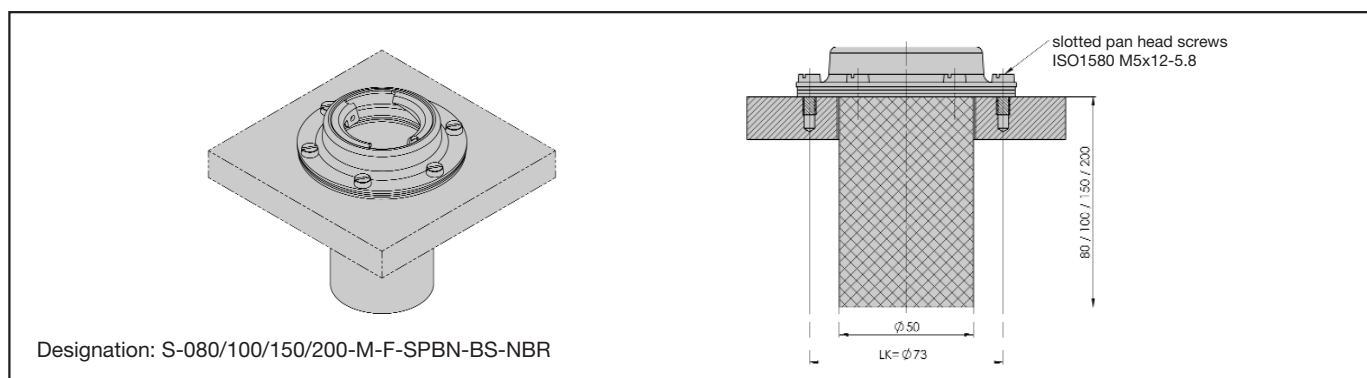

Ordering Code

SPBN - S - 2 - 10 - B12 - A - D300

Type		Dipstick option	
SPBN	Plastic Filler Breather - Narrow Version	(none)	without dipstick
		D300	dipstick 300mm
		Note: The plastic dipstick can be shortened by the customer to requested lengths.	
Version		Anti-splash option	
S	without pressurisation (standard)	A	with anti-splash option (only for screw-in version)
P1	pressurized at 0,20 bar (3 PSI)	O	without anti-splash option (standard)
P2	pressurized at 0,35 bar (5 PSI)		
P3	pressurized at 0,70 bar (10 PSI)		
Group size		Connection	
size	cap diameter	max rate of air flow (m ³ /min)	
2	70	0,4	B12 G ³ / ₄ BSP
			B16 G1 BSP
			N12 3/4 NPT (on request)
			N16 1 NPT (on request)
			BS Bayonet version (without accessories)
			BM Bayonet version (including mounting adaptor, gaskets and bolts)
			S080 BM + 80 mm metal basket
			S100 BM + 100 mm metal basket
			S150 BM + 150 mm metal basket
			S200 BM + 200 mm metal basket
Micronrating and Filter Material			
Code	foam (PUR)		
10	10 µm PUR (standard)		
40	40 µm PUR (standard)		

Airflow plastic filler breathers SPBN 2

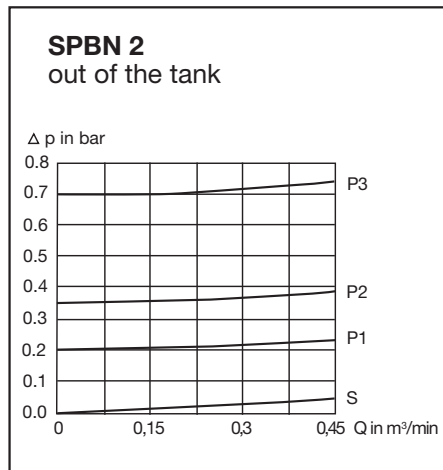
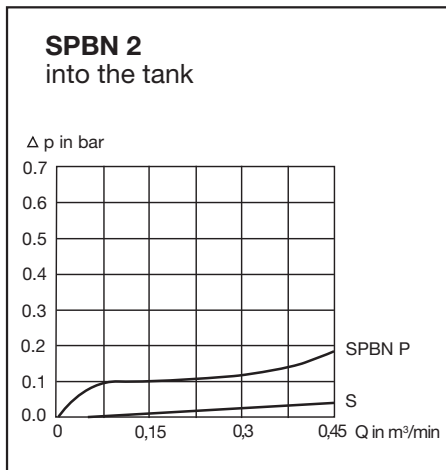



Area of Application:

Ventilation and tank filling

Available Versions:

Screw-in, bayonet and push-on style

Materials:

- Breather cap: steel, chrome-plated (epoxy on request)
- Socket: steel, chrome-plated
- Air filter insert: see order table on page 17
- Basket: steel, zinc-plated
- Seals: Cork, Buna-N (NBR)

Options:

- Metal basket (micron rating 800 µm)
- Thread style BSP and NPT available
- Pressurised at 0,35 or 0,70 bar
- Lockable
- Plastic dipsticks

Custom built combinations and specials are available on request.

Group size 47 – Breather cap diameter 47 mm

SMBB-47

Metal Filler Breather
Bayonet style
Seal material: cork
Options:
• Metall basket

SMBT-47

Metal Breather
Screw-in style
Options:
• BSP- or NPT-thread

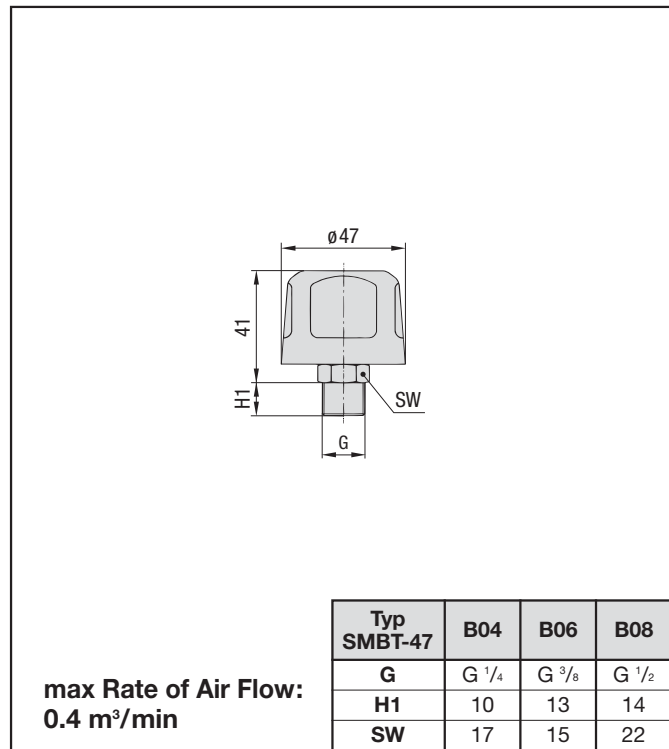
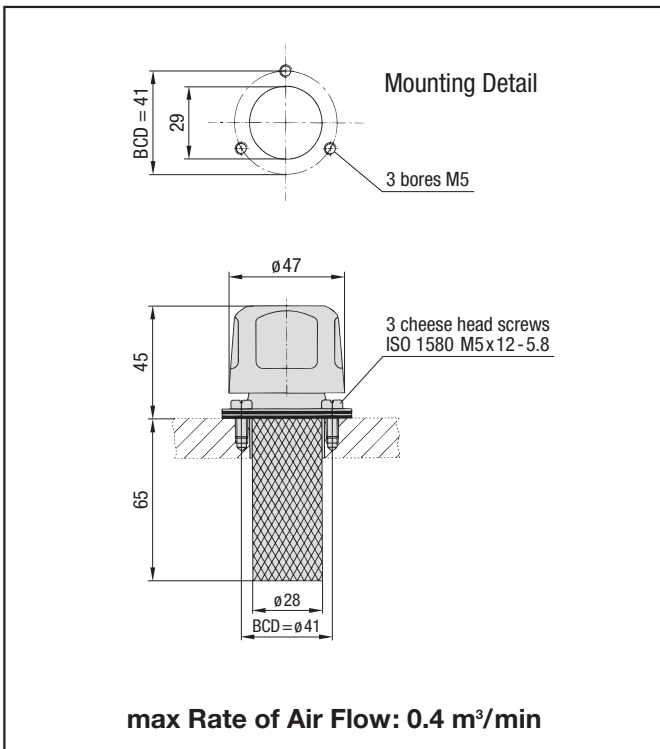

Metal Filler breathers SMBB-47 and SMBT-47 are not lockable, have no pressurisation option and are not available with a dipstick. For more details see order table on page 19.

Ordering Code (bayonet style, cap ø47)

SMBB - 47 - S - 10 - O - C - S065 - O																																																	
<table border="1" style="width: 100%; border-collapse: collapse;"> <tr> <td colspan="2">Typ</td> </tr> <tr> <td style="width: 10%;">SMBB</td> <td>Metal Filler Breather (bayonet style)</td> </tr> </table> <table border="1" style="width: 100%; border-collapse: collapse;"> <tr> <td colspan="2">Cap size</td> </tr> <tr> <td style="width: 10%;">47</td> <td>ø47, steel cap, chrome-plated (standard)</td> </tr> <tr> <td>47E</td> <td>ø47, steel cap, black epoxy</td> </tr> <tr> <td colspan="2">Note: other versions on request</td> </tr> </table> <table border="1" style="width: 100%; border-collapse: collapse;"> <tr> <td colspan="2">Version</td> </tr> <tr> <td style="width: 10%;">S</td> <td>with STAUFF-logo (standard)</td> </tr> <tr> <td>N</td> <td>neutral (without logo)</td> </tr> </table> <table border="1" style="width: 100%; border-collapse: collapse;"> <tr> <td colspan="2">Filter material and micron rating</td> </tr> <tr> <td style="width: 10%;">00</td> <td>without filter insert</td> </tr> <tr> <td>03</td> <td>3 µm filterpaper</td> </tr> <tr> <td>10</td> <td>10 µm foam (PUR, standard)</td> </tr> <tr> <td>40</td> <td>40 µm foam (PUR)</td> </tr> </table>	Typ		SMBB	Metal Filler Breather (bayonet style)	Cap size		47	ø47, steel cap, chrome-plated (standard)	47E	ø47, steel cap, black epoxy	Note: other versions on request		Version		S	with STAUFF-logo (standard)	N	neutral (without logo)	Filter material and micron rating		00	without filter insert	03	3 µm filterpaper	10	10 µm foam (PUR, standard)	40	40 µm foam (PUR)	<table border="1" style="width: 100%; border-collapse: collapse;"> <tr> <td colspan="2">Dipstick</td> </tr> <tr> <td style="width: 10%;">O</td> <td>without dipstick (standard)</td> </tr> </table> <table border="1" style="width: 100%; border-collapse: collapse;"> <tr> <td colspan="2">Baskets</td> </tr> <tr> <td style="width: 10%;">O</td> <td>without baskets</td> </tr> <tr> <td>S065</td> <td>65 mm metal basket (standard)</td> </tr> </table> <table border="1" style="width: 100%; border-collapse: collapse;"> <tr> <td colspan="2">Seal material</td> </tr> <tr> <td style="width: 10%;">C</td> <td>cork</td> </tr> </table> <table border="1" style="width: 100%; border-collapse: collapse;"> <tr> <td colspan="2">Pressurisation (Opening pressure)</td> </tr> <tr> <td style="width: 10%;">O</td> <td>without pressurisation (standard)</td> </tr> <tr> <td colspan="2">Note: No pressurisation available for this cap diameter.</td> </tr> </table>	Dipstick		O	without dipstick (standard)	Baskets		O	without baskets	S065	65 mm metal basket (standard)	Seal material		C	cork	Pressurisation (Opening pressure)		O	without pressurisation (standard)	Note: No pressurisation available for this cap diameter.	
Typ																																																	
SMBB	Metal Filler Breather (bayonet style)																																																
Cap size																																																	
47	ø47, steel cap, chrome-plated (standard)																																																
47E	ø47, steel cap, black epoxy																																																
Note: other versions on request																																																	
Version																																																	
S	with STAUFF-logo (standard)																																																
N	neutral (without logo)																																																
Filter material and micron rating																																																	
00	without filter insert																																																
03	3 µm filterpaper																																																
10	10 µm foam (PUR, standard)																																																
40	40 µm foam (PUR)																																																
Dipstick																																																	
O	without dipstick (standard)																																																
Baskets																																																	
O	without baskets																																																
S065	65 mm metal basket (standard)																																																
Seal material																																																	
C	cork																																																
Pressurisation (Opening pressure)																																																	
O	without pressurisation (standard)																																																
Note: No pressurisation available for this cap diameter.																																																	

Note: Screws are supplied with the SMBB as standard

Ordering Code (screw-in style, cap ø47)

SMBT - 47 - S - 10 - O - B08 - O																																																					
<table border="1" style="width: 100%; border-collapse: collapse;"> <tr> <td colspan="2">Typ</td> </tr> <tr> <td style="width: 10%;">SMBT</td> <td>Metal Filler Breather (screw-in style)</td> </tr> </table> <table border="1" style="width: 100%; border-collapse: collapse;"> <tr> <td colspan="2">Cap size</td> </tr> <tr> <td style="width: 10%;">47</td> <td>ø47, steel cap, chrome-plated (standard)</td> </tr> <tr> <td>47E</td> <td>ø47, steel cap, black epoxy</td> </tr> <tr> <td colspan="2">Note: other versions on request</td> </tr> </table> <table border="1" style="width: 100%; border-collapse: collapse;"> <tr> <td colspan="2">Version</td> </tr> <tr> <td style="width: 10%;">S</td> <td>with STAUFF-logo (standard)</td> </tr> <tr> <td>N</td> <td>neutral (without logo)</td> </tr> </table> <table border="1" style="width: 100%; border-collapse: collapse;"> <tr> <td colspan="2">Filter material and micron rating</td> </tr> <tr> <td style="width: 10%;">00</td> <td>without filter insert</td> </tr> <tr> <td>03</td> <td>3 µm filterpaper</td> </tr> <tr> <td>10</td> <td>10 µm foam (PUR, standard)</td> </tr> <tr> <td>40</td> <td>40 µm foam (PUR)</td> </tr> </table>	Typ		SMBT	Metal Filler Breather (screw-in style)	Cap size		47	ø47, steel cap, chrome-plated (standard)	47E	ø47, steel cap, black epoxy	Note: other versions on request		Version		S	with STAUFF-logo (standard)	N	neutral (without logo)	Filter material and micron rating		00	without filter insert	03	3 µm filterpaper	10	10 µm foam (PUR, standard)	40	40 µm foam (PUR)	<table border="1" style="width: 100%; border-collapse: collapse;"> <tr> <td colspan="2">Dipstick</td> </tr> <tr> <td style="width: 10%;">O</td> <td>without dipstick (standard)</td> </tr> </table> <table border="1" style="width: 100%; border-collapse: collapse;"> <tr> <td colspan="2">Connection thread</td> </tr> <tr> <td style="width: 10%;">B04</td> <td>G 1/4 BSP</td> </tr> <tr> <td>B06</td> <td>G 3/8 BSP</td> </tr> <tr> <td>B08</td> <td>G 1/2 BSP</td> </tr> <tr> <td>N04</td> <td>1/4 NPT (on request)</td> </tr> <tr> <td>N06</td> <td>3/8 NPT (on request)</td> </tr> <tr> <td>N08</td> <td>1/2 NPT (on request)</td> </tr> </table> <table border="1" style="width: 100%; border-collapse: collapse;"> <tr> <td colspan="2">Pressurisation (Opening pressure)</td> </tr> <tr> <td style="width: 10%;">O</td> <td>without pressurisation (standard)</td> </tr> <tr> <td colspan="2">Note: No pressurisation available for this cap diameter.</td> </tr> </table>	Dipstick		O	without dipstick (standard)	Connection thread		B04	G 1/4 BSP	B06	G 3/8 BSP	B08	G 1/2 BSP	N04	1/4 NPT (on request)	N06	3/8 NPT (on request)	N08	1/2 NPT (on request)	Pressurisation (Opening pressure)		O	without pressurisation (standard)	Note: No pressurisation available for this cap diameter.	
Typ																																																					
SMBT	Metal Filler Breather (screw-in style)																																																				
Cap size																																																					
47	ø47, steel cap, chrome-plated (standard)																																																				
47E	ø47, steel cap, black epoxy																																																				
Note: other versions on request																																																					
Version																																																					
S	with STAUFF-logo (standard)																																																				
N	neutral (without logo)																																																				
Filter material and micron rating																																																					
00	without filter insert																																																				
03	3 µm filterpaper																																																				
10	10 µm foam (PUR, standard)																																																				
40	40 µm foam (PUR)																																																				
Dipstick																																																					
O	without dipstick (standard)																																																				
Connection thread																																																					
B04	G 1/4 BSP																																																				
B06	G 3/8 BSP																																																				
B08	G 1/2 BSP																																																				
N04	1/4 NPT (on request)																																																				
N06	3/8 NPT (on request)																																																				
N08	1/2 NPT (on request)																																																				
Pressurisation (Opening pressure)																																																					
O	without pressurisation (standard)																																																				
Note: No pressurisation available for this cap diameter.																																																					

Group size 80 – Breather cap diameter 80 mm

SMBB-80

Metal Filler Breather
Bayonet style
Options:

- Plastic dipstick
- Metal basket
- Lockable
- Pressurised, opening pressure (0,35 or 0,7 bar)
- Seal material: cork or NBR

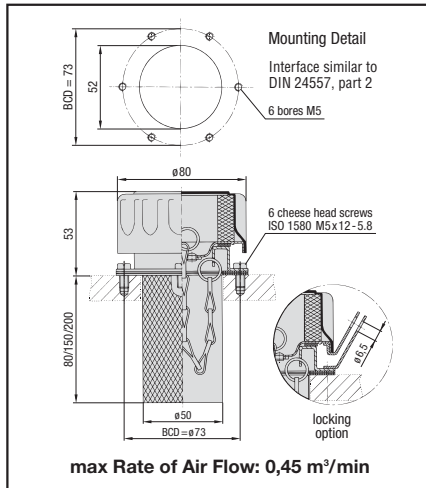

without pressurisation

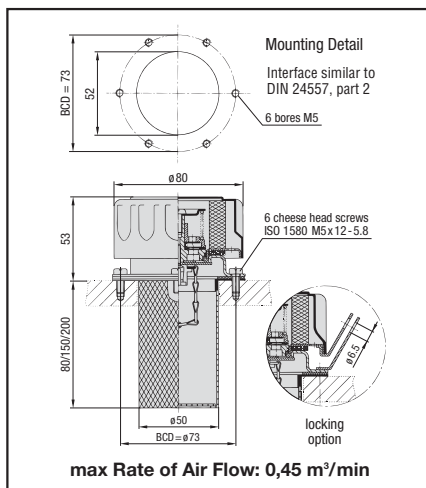

with pressurisation

SMBT-80

Metal Breather
Screw-in style
Options:

- Plastic dipstick
- BSP or NPT thread
- Pressurised, opening pressure (0,35 or 0,7 bar)

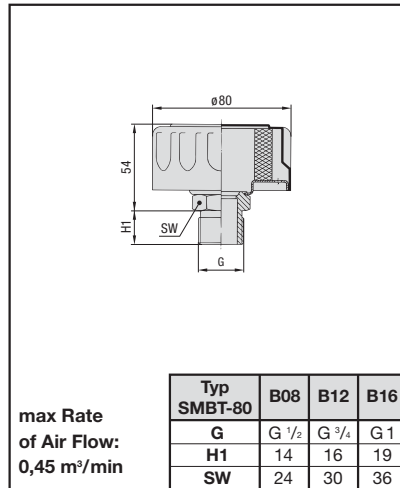

without pressurisation

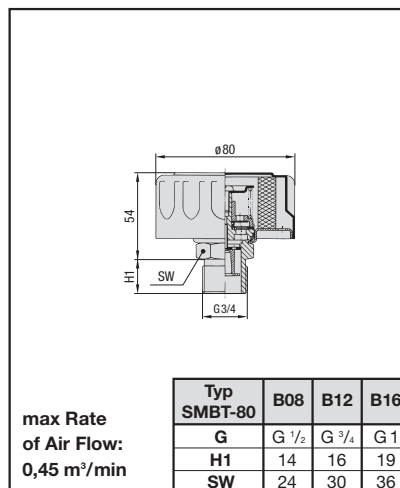

with pressurisation

SMBP-80

Metal Breather
Push-on style
Options:

- Plastic dipstick

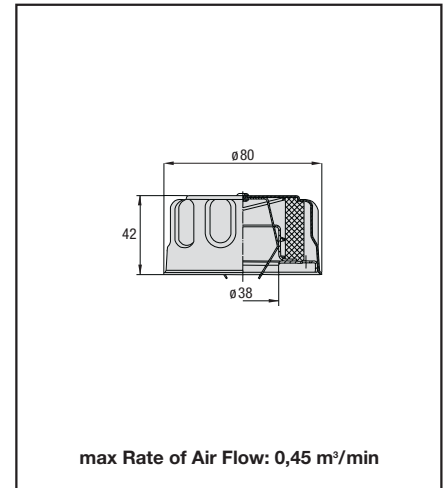

The SMBP is only available without pressurisation

Alternative filter material and micron ratings are available on request for all sizes and versions.

For more details see order table on page 21.

Ordering Code (bayonet style, cap ø80)

SMBB - 80 - S - L - 10 - 05 - B - S080 - O

Typ	
SMBB	Metal Filler Breather (bayonet style)

Cap size	
80	ø80, steel cap, chrome-plated (standard)
80E	ø80, steel cap, black epoxy
Note: other versions on request	

Version	
S	with STAUFF-logo (standard)
N	neutral (without logo)

Locking option	
O	not lockable (standard)
L	lockable

Filter material and micron rating	
00	without filter insert
03	3 µm filterpaper
10	10 µm foam (PUR, standard)
40	40 µm foam (PUR)

Dipstick	
O	without dipstick (standard)
D300	plastic dipstick 300 mm
Note: The plastic dipstick can be shortened by the customer to requested lengths.	

Baskets	
O	without baskets
S080	80 mm metal basket (standard)
S100	100 mm metal basket
S150	150 mm metal basket
S200	200 mm metal basket

Seal material	
C	cork (for non-pressurised version)
B	NBR (for pressurised version)

Pressurisation (Opening pressure)	
O	without pressurisation (standard)
05	0,35 bar (5 PSI)
10	0,70 bar (10 PSI)

Note: Screws are supplied with the SMBB as standard

Ordering Code (screw-in style, cap ø80)

SMBT - 80 - S - 10 - 05 - B08 - O

Typ	
SMBT	Metal Filler Breather (screw-in style)

Cap size	
80	ø80, steel cap, chrome-plated (standard)
80E	ø80, steel cap, black epoxy
Note: other versions on request	

Version	
S	with STAUFF-logo (standard)
N	neutral (without logo)

Filter material and micron rating	
00	without filter insert
03	3 µm filterpaper
10	10 µm foam (PUR, standard)
40	40 µm foam (PUR)

Dipstick	
O	without dipstick (standard)
D300	plastic dipstick 300 mm
Note: The plastic dipstick can be shortened by the customer to requested lengths.	

Connection thread	
B08	G 1/2 BSP
B12	G 3/4 BSP
B16	G 1 BSP
N08	1/2 NPT (on request)
N12	3/4 NPT (on request)
N16	1 NPT (on request)

Pressurisation (Opening pressure)	
O	without pressurisation (standard)
05	0,35 bar (5 PSI)
10	0,70 bar (10 PSI)

Ordering Code (push-on style, cap ø80)

SMBP - 80 - S - 10 - D300

Typ	
SMBP	Metal Filler Breather (push-on style)

Cap size	
80	ø80, steel cap, chrome-plated (standard)
80E	ø80, steel cap, black epoxy
Note: other versions on request	

Version	
S	with STAUFF-logo (standard)
N	neutral (without logo)

Dipstick	
O	without dipstick (standard)
D300	plastic dipstick 300 mm
Note: The plastic dipstick can be shortened by the customer to requested lengths.	

Filter material and micron rating	
00	without filter insert
10	10 µm foam (PUR, standard)
40	40 µm foam (PUR)



Area of Application:

Lateral fastening of filler breathers with flange connection (suitable for SMBB-80, SPB 5 and SPBN 2)

Materials:

- | | | |
|--------------------|--|--|
| | SMBB-ASMB-1 | SMBB-ASMB-2 |
| • Housing: | Polyamide | Aluminium |
| • Seals: | Klingerit | Klingerit |
| • Screws: | Steel, zinc-plated
M6 x 25 ISO 4762 | Steel, zinc-plated
M6 x 25 ISO 4762 |
| • Nuts: | Steel, zinc-plated M6 ISO 4032 | Steel, zinc-plated M6 ISO 4032 |
| • Washers: | Steel, zinc-plated | Steel, zinc-plated |
| • Mounting screws: | Steel, zinc-plated 4.8x13 ISO 7049 | |

Seals, screws, washers and nuts are supplied with the SES-ASMB as standard

Dimensions SMBB-ASMB-1

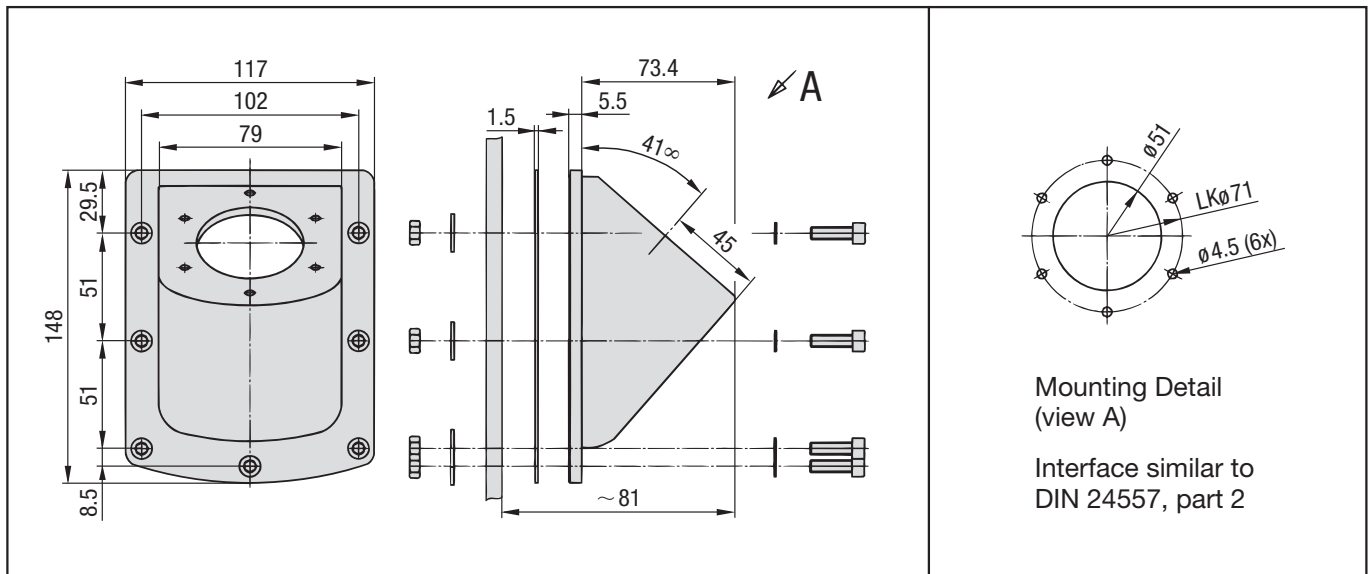

Dimensions SMBB-ASMB-2

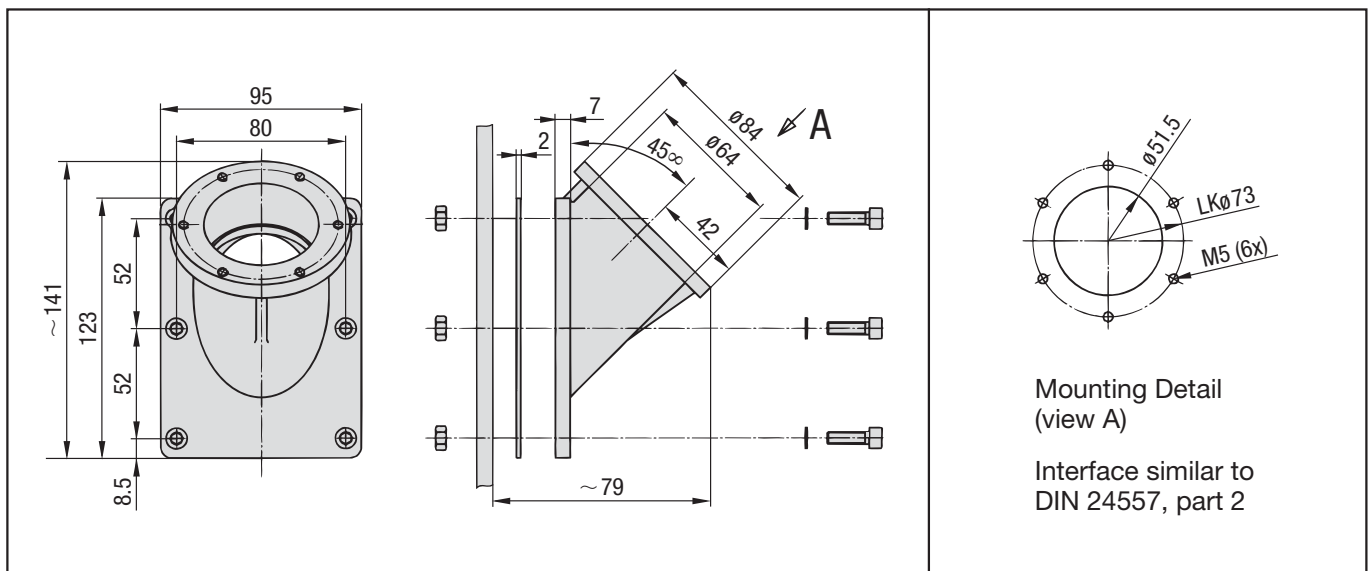

Ordering Code

SMBB-ASMB-1	
Type	Version
SMBB-ASMB Angled side Mounting Bracket for SMBB-80 and SPB 5	1 Housing Polyamide
	2 Housing Aluminium

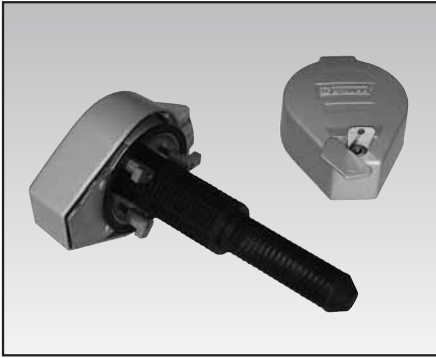

Area of Application:

Ventilation and tank filling

Characteristics/Materials:

- available as thread-style, clamping style and push-on-style
- key-lockable
- Temperature range: - 30°C ... + 100°C
- Materials:
 - Body: die casted Aluminium
 - Baskets: zinc-plated steel or Polypropylene (see ordering code)
 - Seals: NBR, others on request
 - Air filter insert: 10 µm (standard) and 40 µm foam (PUR), others on request
- Including two keys

Dimension

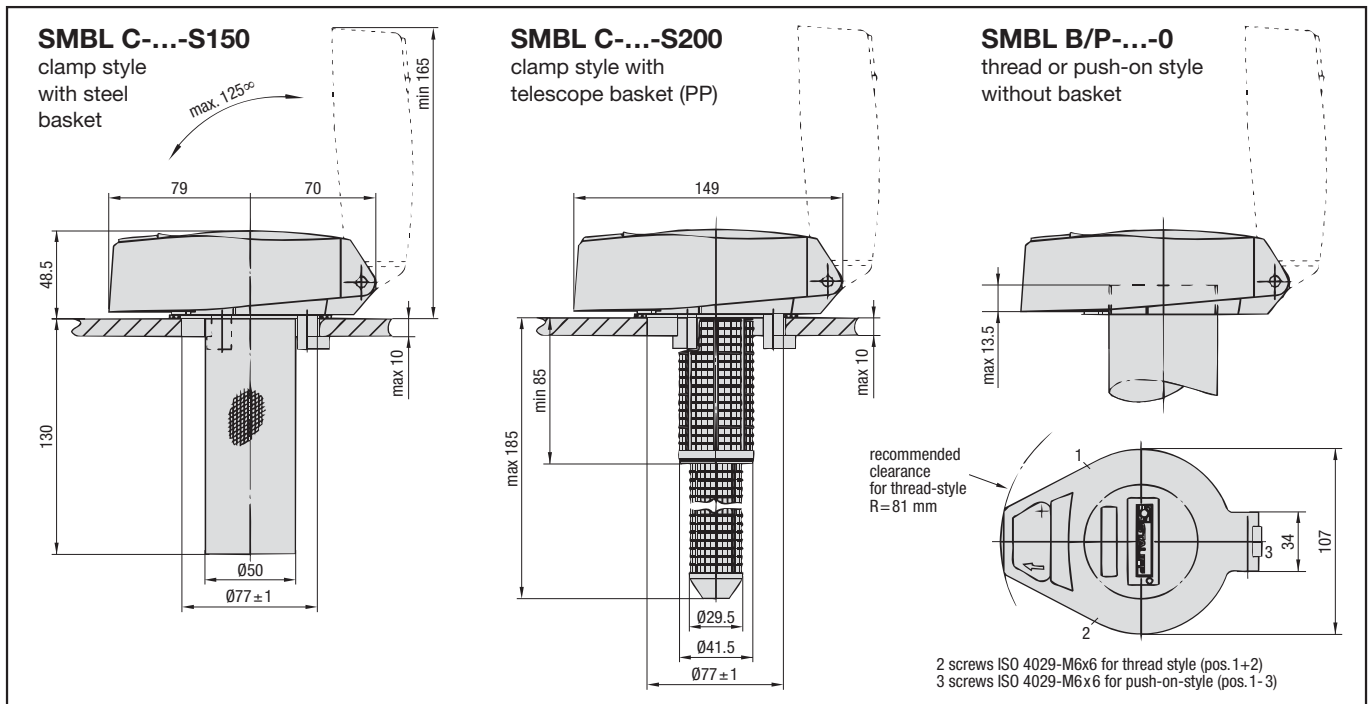

Ordering Code

SMBL C - 10 - 1 - S150 - B - O

Type		Metal cap design	
SMBL	Filler Breather (lockable)	O	lacquered (light grey) RAL 9022 (standard)
Connection		Seal material	
B32	G2 (thread style)	B	NBR (standard)
B40	G2½ (thread style)	V	FPM
C	clamping style	Baskets	
P	push-on-style	O	no basket
Micron rating		S080	plastic basket 80 mm (see page 14)
00	without air filter	S150	steel basket 150 mm (standard)
10	10 micron PUR (standard) air filter	S200	plastic basket 200 mm (see page 14)
40	40 micron PUR air filter	Note: baskets from the SMBB-series cannot be used in conjunction with the SMBL breather type	
Style (Air flow)			
1	air flow in both directions (standard)		
2	no air flow		
3	air flow only into the tank		



Area of Application:

Ventilation and tank filling

Materials:

- Breather cap: PA
- Plastic stud: PA
- Socket: Steel (1.0718)
- Nut: Steel (1.0718); PA available on request
- Air filter insert: Sintered bronze; Rating 45 µm
- Basket PA; micron rating 300 µm
- Dipstick: Steel (1.0718)
- Seals: NBR

Combinations with basket or dipstick.

Dimensions

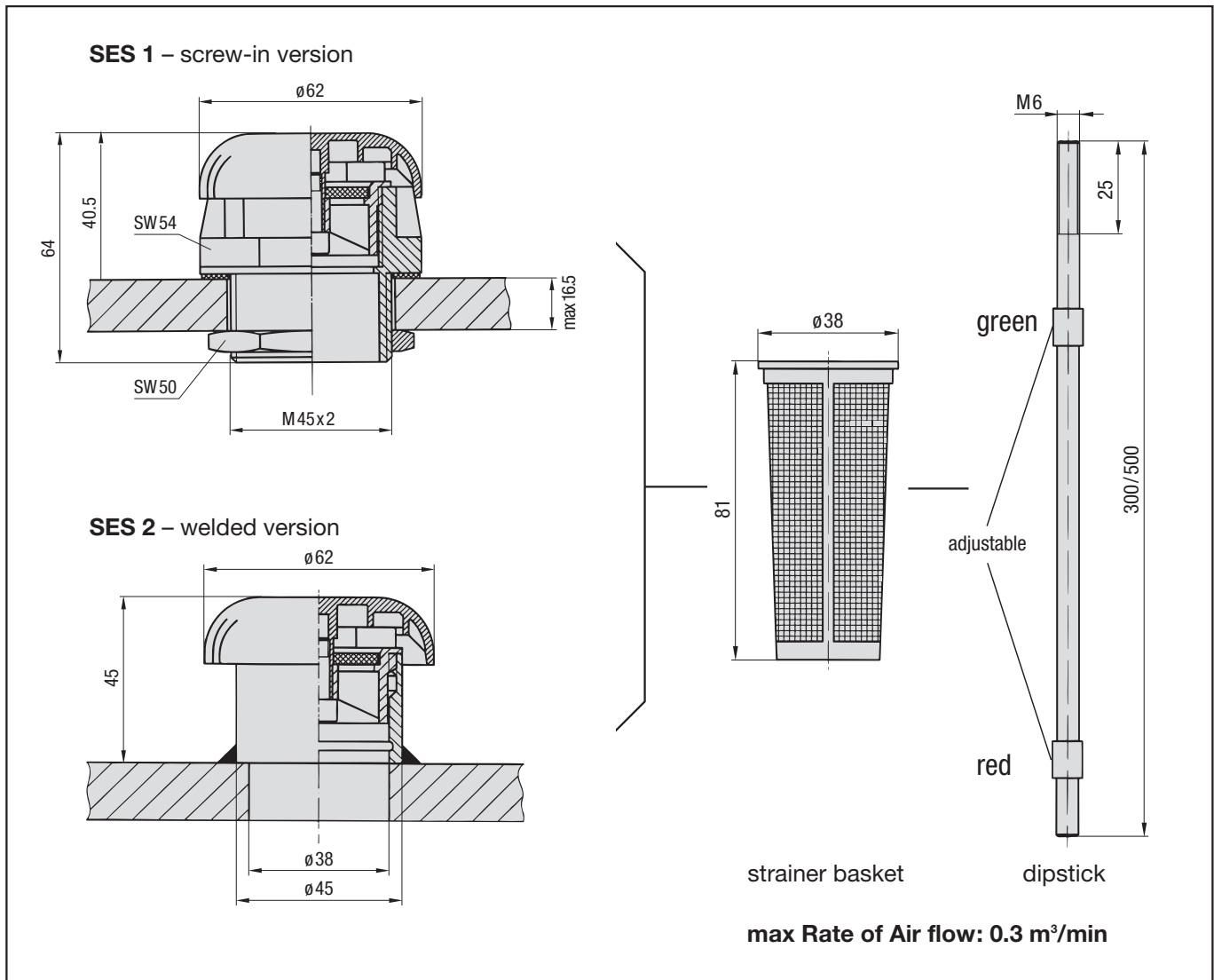

Ordering Code

SES 1 - M300	
Type	Accessories
SES Filler Breather	(none) no accessory
Execution	S Basket, 81 mm
1 screw-in version	M300 Dipstick, 300 mm
2 welded version	M500 Dipstick, 500 mm



Area of Application:

Tank ventilation

Characteristics:

- Standard micron rating: 3 µm glass fibre
- Rate of air flow
 SGB-090: 0.7 m³/min.
 SGB-120: 1.5 m³/min.
- Adaptors*
 TBA-075-B for SGB-090
 TBA-125-B for SGB-120

Also, SGB are designed to be used as air filters for STAUFF desiccant breathers (see pages 26 and 27).

Dimensions SGB

* Adaptors

On request, screw-in adaptors for giant breathers SGB-090 and SGB-120 are available in combination with giant air breathers.

Dimensions TBA

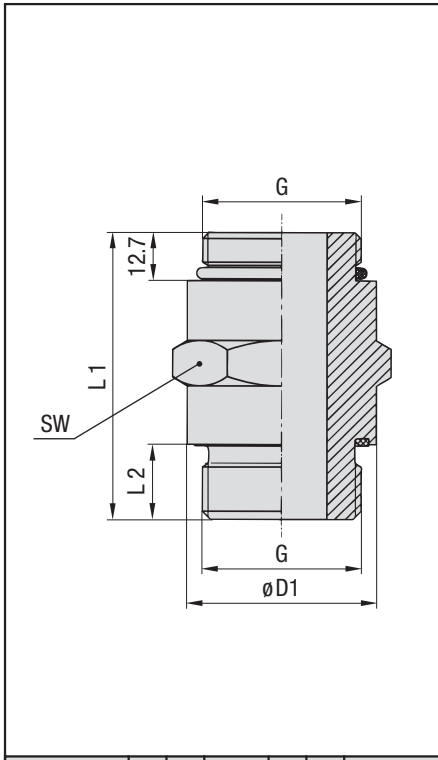

Type	L1	L2	G	D1	SW	O-Ring
TBA-075-B	57	16	G ³ / ₄	32	32	ø23.5x3
TBA-125-B	76	20	G1 ¹ / ₄	50	50	ø38.5x3

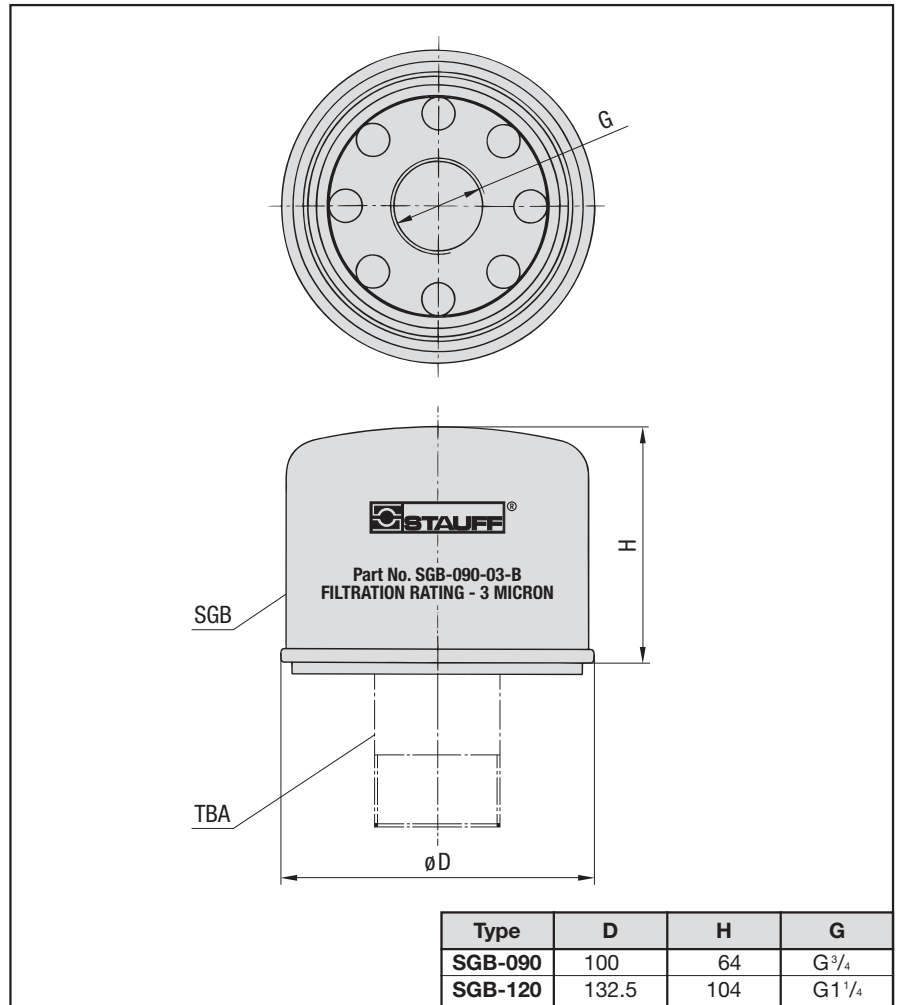

Type	D	H	G
SGB-090	100	64	G ³ / ₄
SGB-120	132.5	104	G1 ¹ / ₄

Ordering Code

SGB - 090 - 03 - B - A

Type	Adaptor option	
SGB Giant air breather	(none) without adaptor	
	A with adaptor TBA	
Version	Thread form	
090 SGB-090	B BSP	
120 SGB-120	Micron rating	
	03 3 µm (standard)	



Area of Application:

Ventilation of the tank with moisture absorption and air filtration.

Characteristics:

- available in 4 executions
- temperature range: max 70°C
- refillable with drying agent (available separately)
- can be delivered complete with adaptor plates and contamination indicator
- replacement air filter insert SGB separately available (see page 25)

Easy hygroscopic indication is possible with the drying agent's capability to change colours with increasing moisture.

Functions:

First, the moisture in the incoming air is absorbed when passing through the drying agent. After passing through the drying agent the dirt particles are caught in the air filter element. With the moisture absorbed, the oxidation process in the hydraulic system will be decreased and the life of the oil and the machine will be extended.

Hygroscopic indication:

As moisture is absorbed, the drying agent granules will gradually change colour from red to orange. An optional indicator also shows the remaining capacity of the air filter element. When the granules change colour to orange, change them.

Note:

At the bottom, desiccant air breathers are sealed with a foil or plastic plugs. These have to be removed before installation!

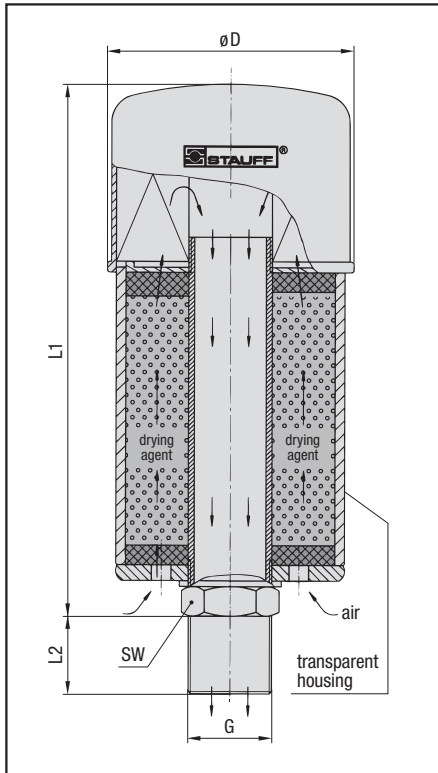

Desiccant air breathers SDB do not contain any dangerous substances according to EC Council directive 88/379/EEC.

Dimensions and Technical Data

	SDB-093	SDB-096	SDB-121	SDB-122
D	100	100	123,5	123,5
L1	160	220	256	366
L2	20	20	min 25	min 25
G	G ^{3/4}	G ^{3/4}	G 1 ^{1/4}	G 1 ^{1/4}
SW	32	32	50	50
max. Rate of air flow (m ³ /min)	0,7	0,7	1,5	1,5
Air filter micron rating (µm)	3	3	3	3
Weight of complete breather (g)	1200	1500	2700	4000
Volume drying agent (cm ³)	300	600	1000	2000
Drying agent filling weight (g)	225	450	750	1500
max hygroscopicity (g)	86	172	288	576

Adaptor Plates AP (only SDB)

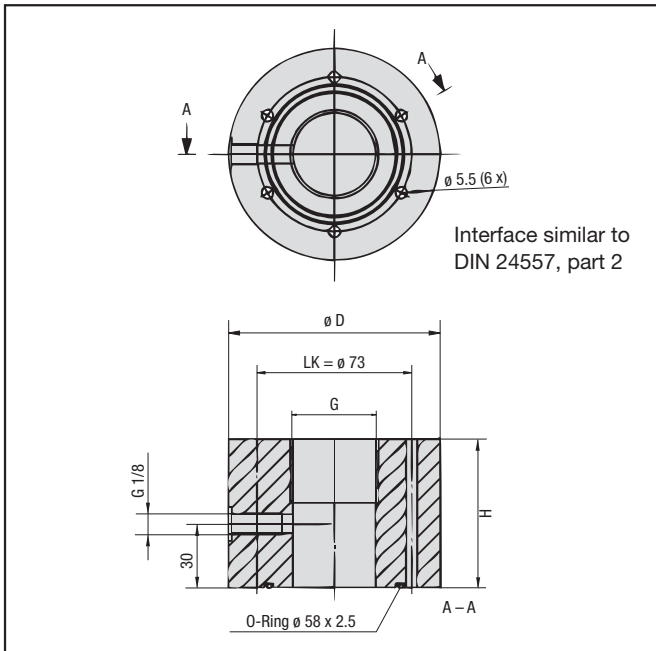

Adaptor Plates AP: With AP plastic adaptor plates desiccant air breathers type SDB can directly be mounted to existing connections. Adaptor plates AP are provided with a thread connection for the optical contamination indicator FM. Plug, O-ring and socket cap screws (ISO 4762) are supplied with AP as a standard.

	AP-1	AP-2
D	88	100
H	50	70
G	G ^{3/4}	G ^{1/4}

Contamination Indicator FM

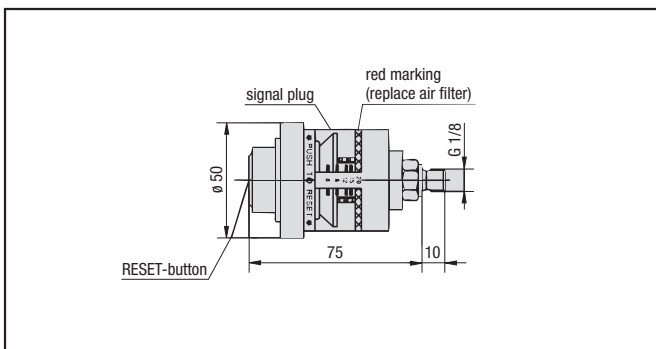

Contamination Indicator FM: The FM indicates the contamination level of the air breathers SGB. You can restore the indicator by pressing the RESET knob for re-use.

Ordering Code

SDB - 122 - AP - FM

Typ	SDB Desiccant air breather										
Size	<table border="1" style="width: 100%; border-collapse: collapse;"> <tr> <td>093</td> <td>hygroscopicity 86g ø100 mm</td> </tr> <tr> <td>096</td> <td>hygroscopicity 172g ø100 mm</td> </tr> <tr> <td>121</td> <td>hygroscopicity 288g ø123,5 mm</td> </tr> <tr> <td>122</td> <td>hygroscopicity 576g ø123,5 mm</td> </tr> </table>	093	hygroscopicity 86g ø100 mm	096	hygroscopicity 172g ø100 mm	121	hygroscopicity 288g ø123,5 mm	122	hygroscopicity 576g ø123,5 mm		
093	hygroscopicity 86g ø100 mm										
096	hygroscopicity 172g ø100 mm										
121	hygroscopicity 288g ø123,5 mm										
122	hygroscopicity 576g ø123,5 mm										
Adaptor plate	<table border="1" style="width: 100%; border-collapse: collapse;"> <tr> <td>(none)</td> <td>without adaptor or adaptor plate</td> </tr> <tr> <td>AP</td> <td>with adaptor plate</td> </tr> </table>	(none)	without adaptor or adaptor plate	AP	with adaptor plate						
(none)	without adaptor or adaptor plate										
AP	with adaptor plate										
Contamination indicator (in conjunction with AP only)	<table border="1" style="width: 100%; border-collapse: collapse;"> <tr> <td>(none)</td> <td>without contamination indicator</td> </tr> <tr> <td>FM</td> <td>optical contamination indicator</td> </tr> </table>	(none)	without contamination indicator	FM	optical contamination indicator						
(none)	without contamination indicator										
FM	optical contamination indicator										

Spare parts	
AP-1	adaptor plate for SDB-093/096
AP-2	adaptor plate for SDB-121/122
FM	contamination indicator for all sizes
RD-093	Drying agent refilling material for SDB-093
RD-096	Drying agent refilling material for SDB-096
RD-121	Drying agent refilling material for SDB-121
RD-122	Drying agent refilling material for SDB-122
SGB-090-03-B	Replacement air filter insert for SDB-093/096
SGB-120-03-B	for SDB-093/096 for SDB-121/122



Area of Application:

Reservoir installation for direct suction line connection

Characteristics:

- Suitable for mineral oil
- Threads forms BSP and NPT
- Filter material 60, 125 or 250 micron stainless steel
- Temperature range $-20^{\circ}\text{C} \dots +100^{\circ}\text{C}$
- Optional bypass valve, opening pressure 0,2 bar (3 PSI)
- Threaded end caps made out of glass fiber reinforced Polyamide (P) or Aluminium (A) (see table below), other components steel zinc-plated

STAUFF-Suction Strainers SUS are available with an integrated bypass valve. Other special configurations on request.

Dimensions

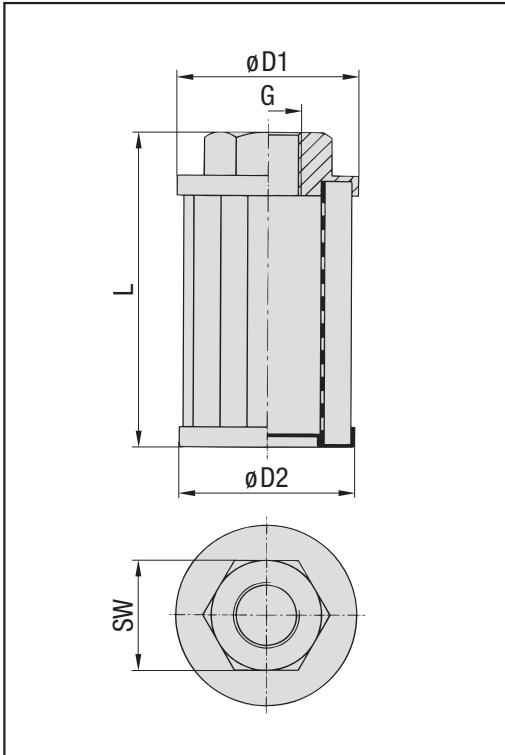

Group size ø upper endcap	thread- code	element- length	Dimensions				Q max l/min	available end cap material			
			D1	D2	G	SW			L		
040 - B06F - 075			39,5	38,5	3/8 BSP	22	75	8	P		
050 - B06F - 067			50	49	3/8 BSP	26	67	10	P		
050 - N06F - 067					3/8 NPT		90	11	P		
050 - N06F - 090									P		
050 - B08F - 105					1/2 BSP	34	105	15	P		
050 - N08F - 105					1/2 NPT					A,P	
068 - B12F - 105			68	66	3/4 BSP	42	105	25	P		
068 - N12F - 105					3/4 NPT						A,P
068 - B16F - 140					1 BSP	50	140	50	P		
068 - N16F - 140					1 NPT					A,P	
088 - B20F - 140			88	85	1 1/4 BSP	60	140	65	P		
088 - N20F - 140					1 1/4 NPT						A,P
088 - N20F - 195							195	88	A,P		
088 - B24F - 140					1 1/2 BSP	70	140	95	P		
088 - N24F - 140					1 1/2 NPT					A,P	
088 - N24F - 226							226	120	A,P		
088 - N24F - 260							260	198	A,P		
088 - N32F - 260					2 NPT				A		
102 - B24F - 200			102	100	1 1/2 BSP	72	200	200	P		
102 - N24F - 200					1 1/2 NPT						P
102 - B32F - 200									P		
102 - B32F - 225					2 BSP	86	225	225	P		
102 - B32F - 260								260	260	P	
102 - B32F - 300							300	300	P		
102 - N32F - 260					2 NPT		260	260	P		
131 - B40F - 191			131	128	2 1/2 BSP	96	191	290	P		
131 - B40F - 212					2 1/2 NPT				212	300	P
131 - N40F - 212									P		
131 - B48F - 272					3 BSP	100	272	380	P		
131 - N48F - 272					3 NPT					P	
150 - B32F - 151			150	145	2 BSP	70	151	260	P		
150 - N40F - 213					2 1/2 NPT				213	283	A
150 - N48F - 272					3 NPT				272	380	A

Hydraulic Symbol

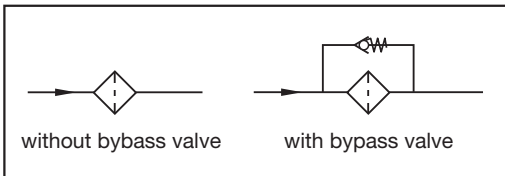

Ordering Code

SUS - P - 088 - B24F - 140 - 125 - 0											
<table border="1"> <tr><td>Typ</td><td>SUS Suction Strainer</td></tr> </table>	Typ	SUS Suction Strainer	<table border="1"> <tr><td>Bypass Option</td><td>0 without bypass (standard)</td></tr> <tr><td></td><td>3 integrated bypass valve (0,2 bar / 3 PSI)</td></tr> </table>	Bypass Option	0 without bypass (standard)		3 integrated bypass valve (0,2 bar / 3 PSI)				
Typ	SUS Suction Strainer										
Bypass Option	0 without bypass (standard)										
	3 integrated bypass valve (0,2 bar / 3 PSI)										
<table border="1"> <tr><td>Material Threaded End Cap</td><td>P glass fiber reinforced Polyamide (standard)</td></tr> <tr><td></td><td>A Aluminium (only for NPT thread, see table)</td></tr> </table>	Material Threaded End Cap	P glass fiber reinforced Polyamide (standard)		A Aluminium (only for NPT thread, see table)	<table border="1"> <tr><td>Micron Rating</td><td>060 60 µm (on request)</td></tr> <tr><td></td><td>125 125 µm (standard)</td></tr> <tr><td></td><td>250 250 µm (on request)</td></tr> </table>	Micron Rating	060 60 µm (on request)		125 125 µm (standard)		250 250 µm (on request)
Material Threaded End Cap	P glass fiber reinforced Polyamide (standard)										
	A Aluminium (only for NPT thread, see table)										
Micron Rating	060 60 µm (on request)										
	125 125 µm (standard)										
	250 250 µm (on request)										
<table border="1"> <tr><td>Group Size</td><td>see table above, column group size</td></tr> </table>	Group Size	see table above, column group size									
Group Size	see table above, column group size										

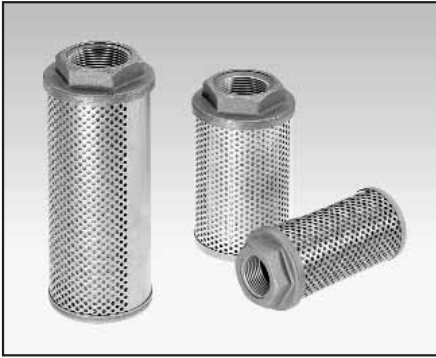

Area of Application:

Foaming and noise reduction in tanks

Characteristics:

- suitable for mineral oil
- reduce fluid aeration
- silencing
- standard thread form: BSP
- consist of two concentric tubes with discharge holes

STAUFF-Diffusers SRV are available with NPT threads on request.

Technical Data

Temperature range: -20°C ... +100°C
 Flow range: 950 l/min max
 Connection thread sizes: G^{3/4} – G3
 End cap material: Aluminium
 Body material: Steel, zinc-plated

Dimensions

Example of Application SRV

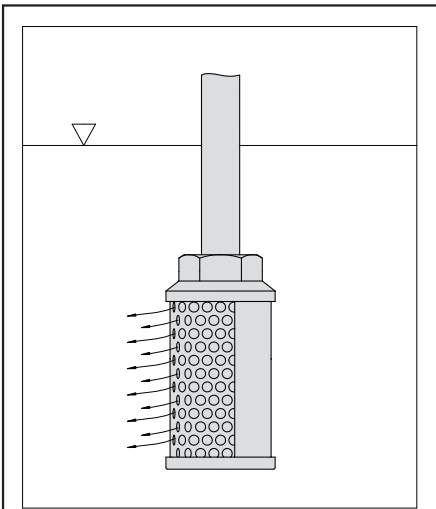

Note

SRV must be completely installed below the liquid level. Its plain area on the outside must be facing the pump inlet.

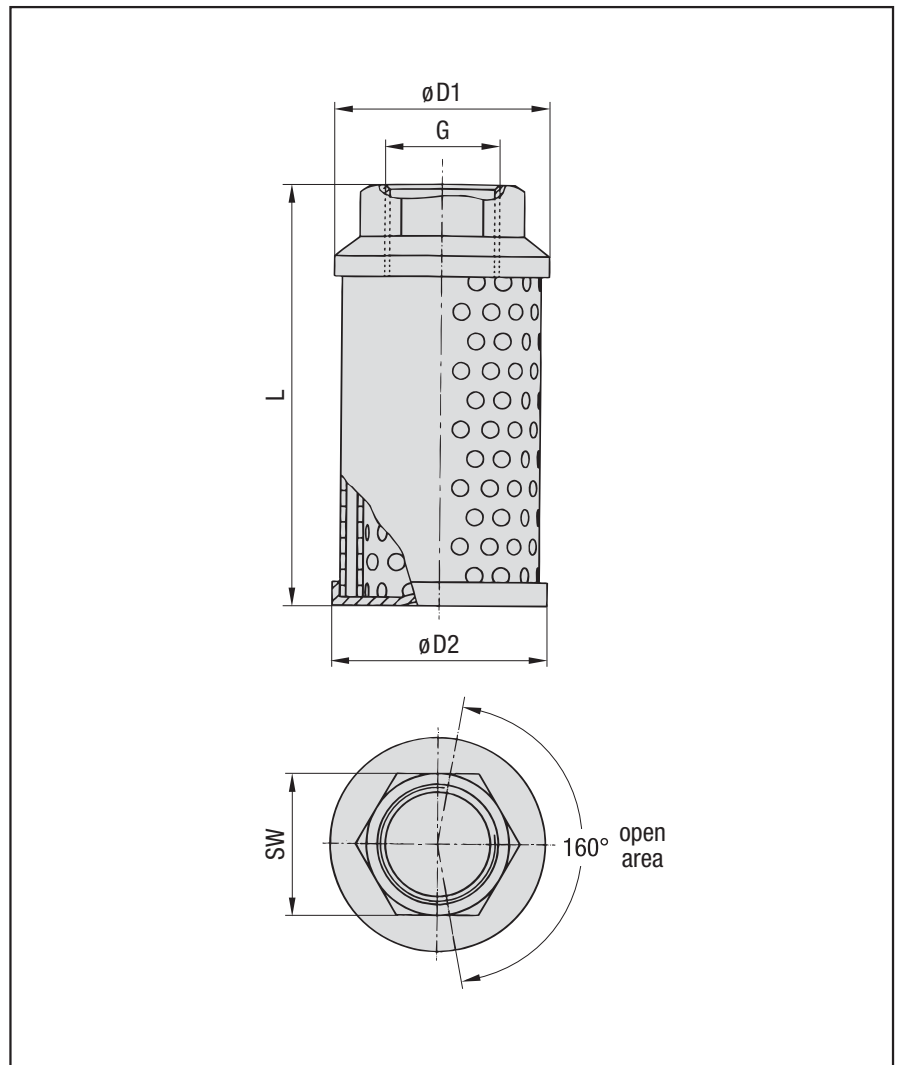

Ordering Code and Dimensional Table

Type	Q max	G	L	D1	D2	SW
SRV-050-B12	50 l/min	G ^{3/4}	109	64	60	36
SRV-114-B16	114 l/min	G1	139	64	60	46
SRV-200-B20	200 l/min	G1 ^{1/4}	139	86	82	60
SRV-227-B24	227 l/min	G1 ^{1/2}	200	86	82	60
SRV-454-B32	454 l/min	G2	260	86	82	70
SRV-650-B40	650 l/min	G2 ^{1/2}	211	150	145	90
SRV-950-B48	950 l/min	G3	272	150	145	100



Area of Application:

Flow, pressure and temperature measuring of fluids (mobile and industrial hydraulics), also controlling of working pressure (only SDMK)

Characteristics:

- suitable for mineral oil (Aluminium), HFC fluids and water (Bronze)
- designed for in-line installation
- mechanical process (off the line)
- controlling working pressure with a pressure control valve (only SDMK)
- flow indication in l/min and GPM
- thread to connect with pressure gauge (only SDM)

Dimensions SDM-750

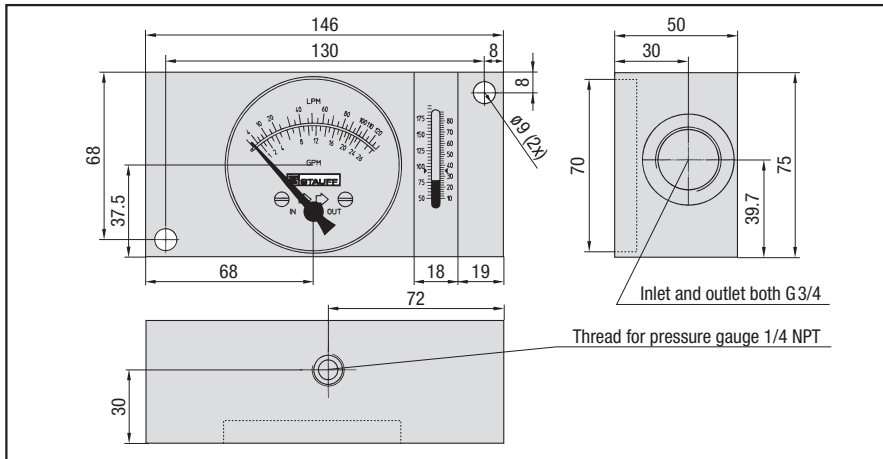

Dimensions SDM-1500

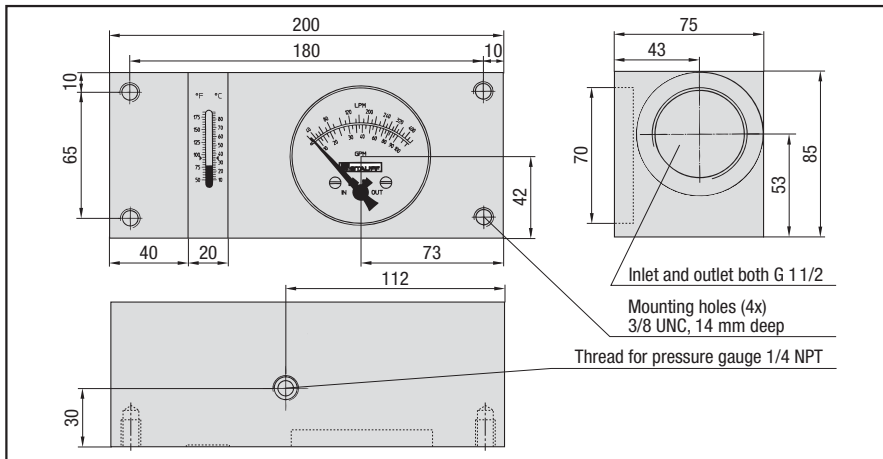

Dimensions SDM-750

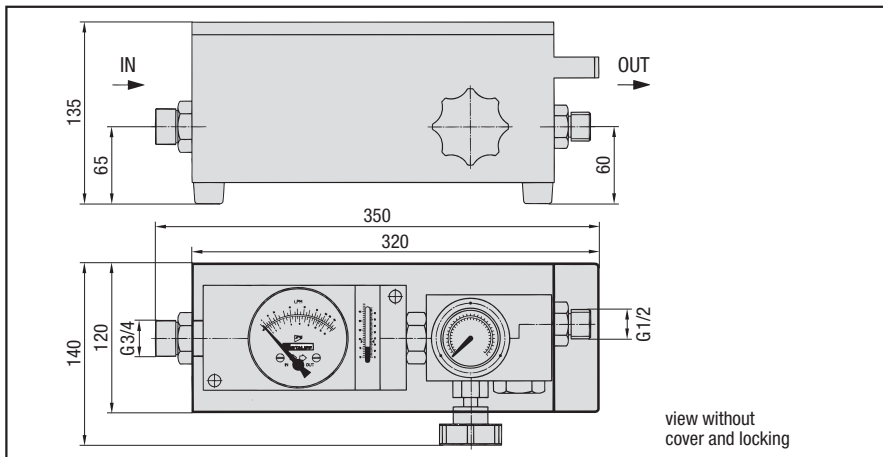

Functional principal flow measuring

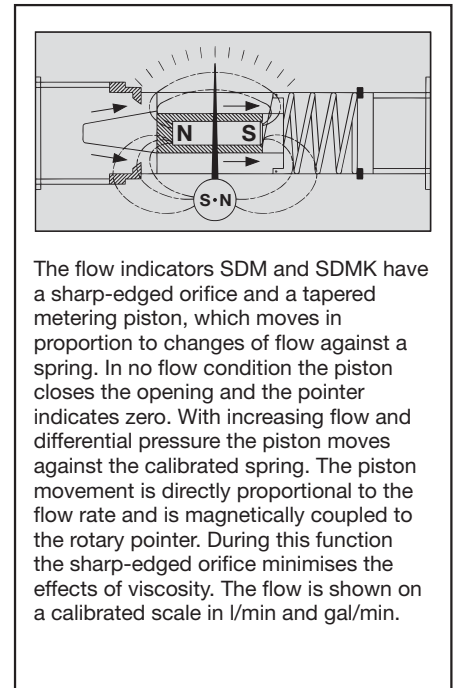

The flow indicators SDM and SDMK have a sharp-edged orifice and a tapered metering piston, which moves in proportion to changes of flow against a spring. In no flow condition the piston closes the opening and the pointer indicates zero. With increasing flow and differential pressure the piston moves against the calibrated spring. The piston movement is directly proportional to the flow rate and is magnetically coupled to the rotary pointer. During this function the sharp-edged orifice minimises the effects of viscosity. The flow is shown on a calibrated scale in l/min and gal/min.

Controlling working pressure with SDMK

The pressure control valve of the SDMK is directly connected to a flow-block and together with the integrated pressure gauge it allows an exact control of the working pressure in the maximum range. For protection the SDMK has two rupture disks. At a pressure of 440 bar the disks burst and the fluid is by-passed around the valve. The rupture disks (other pressure ranges on request) can be replaced easily.

Technical Data

Accuracy:	
Flow:	± 4 % FSD
Temperature:	± 2 °C
Pressure (only SDMK):	± 1.6 % of max pressure
Temperature measuring range:	10 °C ... 80 °C

Technical Data

Part Number	max Working press.	Flow range	Weight	Connection	Dimensions (mm)
SDM-750-A-016-T	420 bar	1 – 16 l/min	1.360 kg	G ³ / ₄	146 x 75 x 50
SDM-750-A-030-T	420 bar	2 – 30 l/min	1.360 kg	G ³ / ₄	146 x 75 x 50
SDM-750-A-060-T	420 bar	3 – 60 l/min	1.360 kg	G ³ / ₄	146 x 75 x 50
SDM-750-A-120-T	420 bar	5 – 120 l/min	1.360 kg	G ³ / ₄	146 x 75 x 50
SDM-750-A-180-T	420 bar	10 – 180 l/min	1.360 kg	G ³ / ₄	146 x 75 x 50
SDM-750-B-030-T	420 bar	2 – 35 l/min	4.250 kg	G ³ / ₄	146 x 75 x 50
SDM-750-B-060-T	420 bar	3 – 70 l/min	4.250 kg	G ³ / ₄	146 x 75 x 50
SDM-750-B-120-T	420 bar	5 – 140 l/min	4.250 kg	G ³ / ₄	146 x 75 x 50
SDM-1500-A-200-T	280 bar	10 – 200 l/min	3.000 kg	G1 ¹ / ₂	200 x 85 x 75
SDM-1500-A-300-T	280 bar	20 – 300 l/min	3.000 kg	G1 ¹ / ₂	200 x 85 x 75
SDM-1500-A-400-T	280 bar	30 – 400 l/min	3.000 kg	G1 ¹ / ₂	200 x 85 x 75
SDM-1500-B-200-T	280 bar	10 – 200 l/min	8.000 kg	G1 ¹ / ₂	200 x 85 x 75
SDM-1500-B-400-T	280 bar	30 – 400 l/min	8.000 kg	G1 ¹ / ₂	200 x 85 x 75
SDMK-750-A-030-T	420 bar	2 – 30 l/min	4.500 kg	G ³ / ₄ + G ¹ / ₂	350 x 135 x 140
SDMK-750-A-060-T	420 bar	3 – 60 l/min	4.500 kg	G ³ / ₄ + G ¹ / ₂	350 x 135 x 140
SDMK-750-A-120-T	420 bar	5 – 120 l/min	4.500 kg	G ³ / ₄ + G ¹ / ₂	350 x 135 x 140
SDMK-750-A-180-T	420 bar	10 – 180 l/min	4.500 kg	G ³ / ₄ + G ¹ / ₂	350 x 135 x 140

Flow Curves

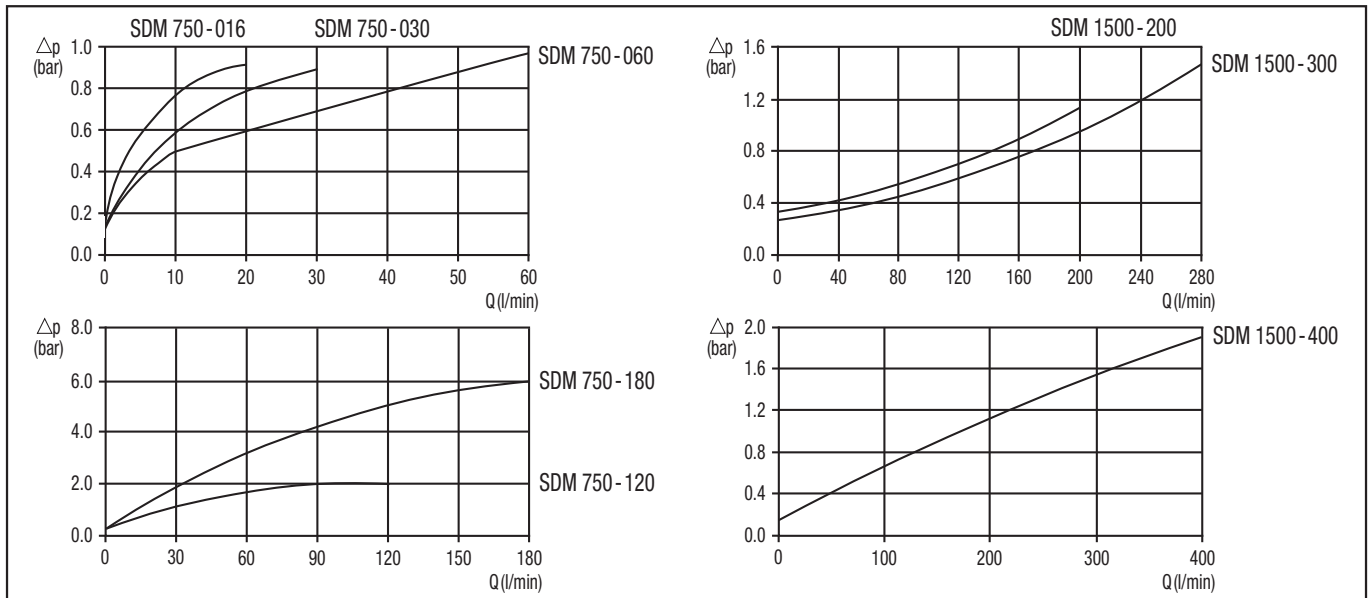

Ordering Code

SDM 750 - A - 016 - T

<table border="1"> <tr><th colspan="2">Type</th></tr> <tr><td>SDM</td><td>Flow Indicator</td></tr> <tr><td>SDMK</td><td>Flow Indicator with pressure control valve</td></tr> </table> <table border="1"> <tr><th colspan="2">Size</th></tr> <tr><td>750</td><td>size 750</td></tr> <tr><td>1500</td><td>size 1500 (only SDM)</td></tr> </table> <table border="1"> <tr><th colspan="2">Housing</th></tr> <tr><td>A</td><td>Aluminium</td></tr> <tr><td>B</td><td>Bronze (only SDM)</td></tr> </table>	Type		SDM	Flow Indicator	SDMK	Flow Indicator with pressure control valve	Size		750	size 750	1500	size 1500 (only SDM)	Housing		A	Aluminium	B	Bronze (only SDM)	<table border="1"> <tr><th colspan="2">Thermometer</th></tr> <tr><td>T</td><td>with integrated thermometer (standard)</td></tr> </table> <table border="1"> <tr><th colspan="2">Flow</th></tr> <tr><td>016</td><td>1 – 16 l/min (size 750, SDM and "A" only)</td></tr> <tr><td>030</td><td>2 – 30 l/min (size 750)</td></tr> <tr><td>060</td><td>3 – 60 l/min (size 750)</td></tr> <tr><td>120</td><td>5 – 120 l/min (size 750)</td></tr> <tr><td>180</td><td>10 – 180 l/min (size 750, "A" only)</td></tr> <tr><td>200</td><td>10 – 200 l/min (size 1500)</td></tr> <tr><td>300</td><td>20 – 300 l/min (size 1500, "A" only)</td></tr> <tr><td>400</td><td>20 – 400 l/min (size 1500)</td></tr> </table>	Thermometer		T	with integrated thermometer (standard)	Flow		016	1 – 16 l/min (size 750, SDM and "A" only)	030	2 – 30 l/min (size 750)	060	3 – 60 l/min (size 750)	120	5 – 120 l/min (size 750)	180	10 – 180 l/min (size 750, "A" only)	200	10 – 200 l/min (size 1500)	300	20 – 300 l/min (size 1500, "A" only)	400	20 – 400 l/min (size 1500)
Type																																									
SDM	Flow Indicator																																								
SDMK	Flow Indicator with pressure control valve																																								
Size																																									
750	size 750																																								
1500	size 1500 (only SDM)																																								
Housing																																									
A	Aluminium																																								
B	Bronze (only SDM)																																								
Thermometer																																									
T	with integrated thermometer (standard)																																								
Flow																																									
016	1 – 16 l/min (size 750, SDM and "A" only)																																								
030	2 – 30 l/min (size 750)																																								
060	3 – 60 l/min (size 750)																																								
120	5 – 120 l/min (size 750)																																								
180	10 – 180 l/min (size 750, "A" only)																																								
200	10 – 200 l/min (size 1500)																																								
300	20 – 300 l/min (size 1500, "A" only)																																								
400	20 – 400 l/min (size 1500)																																								



Area of Application: mechanical pressure measurement

Characteristics:

- suitable for hydraulic oil and gaseous media that do not attack any copper base alloy
- available in nominal sizes 63 and 100
- standard thread form: BSP
- housing made out of stainless steel (1.4301)
- sight glass made out of acrylic
- glycerine filled
- standard dual scales with pressure indication in bar and PSI
- U-bolt or flange mounting kit on request

Please consult our office before you use SPG with other media.

Technical Data:

pressure gauge according to EN 837-1

system of protection: IP 65 (EN 60 529 / IEC 529)

accuracy class SPG-063: 1.6 (± 1.6 % FS as per EN 837-1)

accuracy class SPG-100: 1.0 (± 1.0 % FS as per EN 837-1)

environmental temp. range: -20°C ... +60°C

temperature range medium: max +60°C

subject to technical modifications

Options (on request):

- additional scale readings including personalisation
- thread form NPT
- U-bolt and flange mounting kits are available separately as spare parts
- additional pressure ranges up to 1000 bar max

Dimensions SPG 063

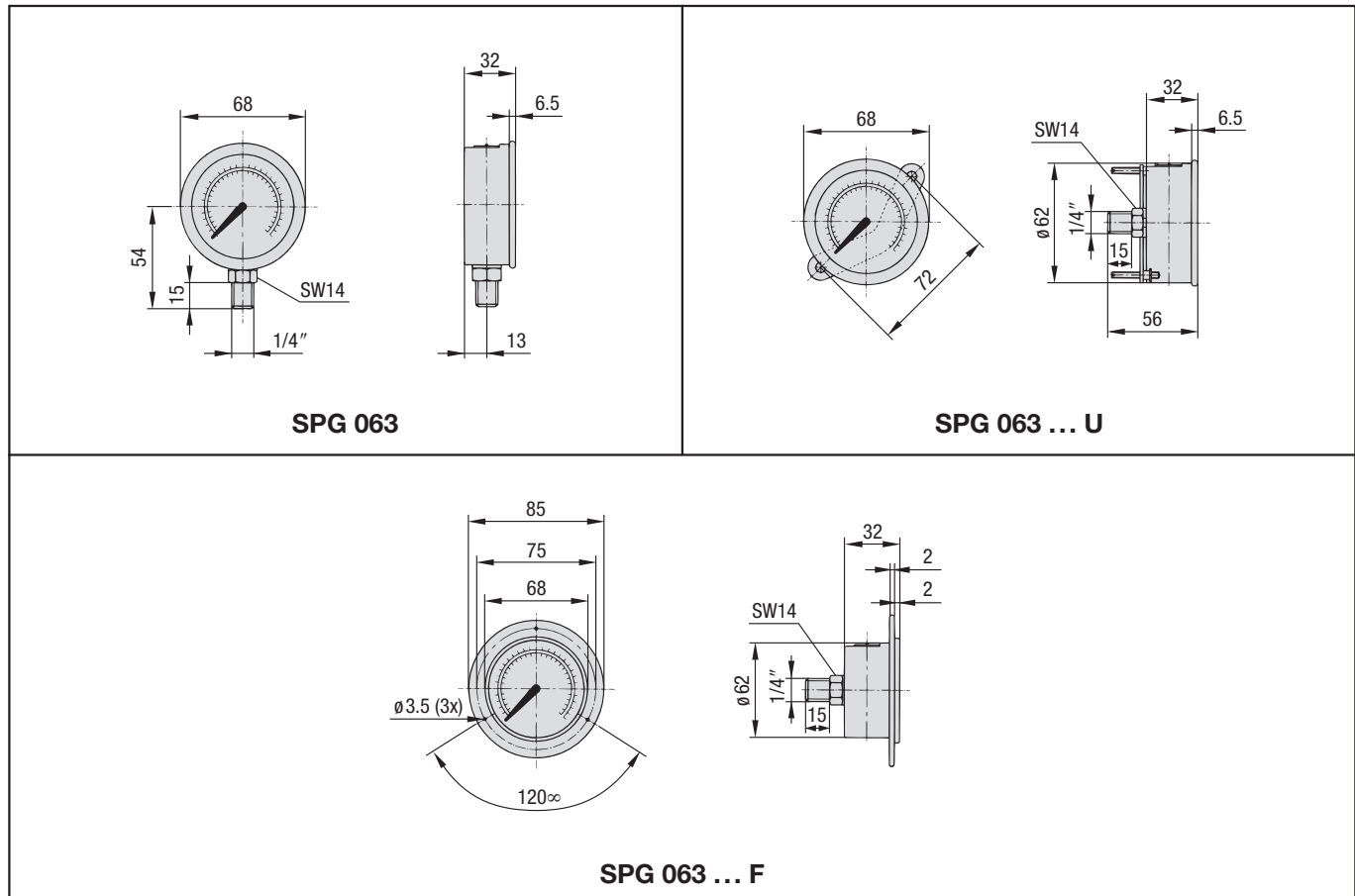

Dimensions SPG 100

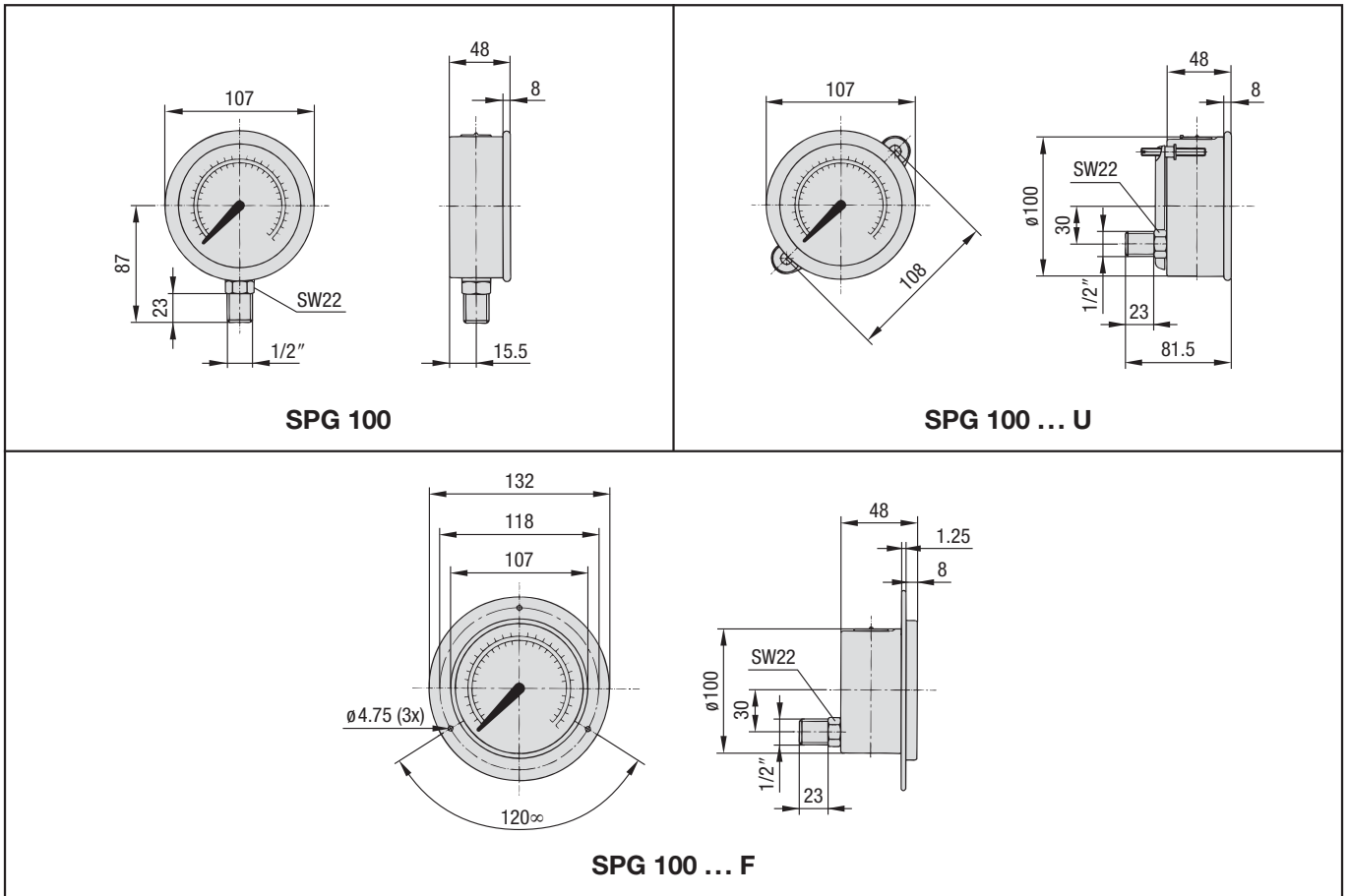

Ordering Code

SPG 063 - 00160 - 01 - P - B04 - U

Type		Accessories (for panel mount only)	
SPG	Stainless steel pressure gauge	(none)	no accessory
Size		U	U-bolt assembly
063	63 mm with G 1/4 or 1/4 NPT connection	F	front flange assembly
100	100 mm with G 1/2 or 1/2 NPT connection	R	rear flange assembly
Pressure range		UF	U-bolt and front flange assembly
Code	Pressure range	Thread size	
(-1)00001	(-1) - 1,5 bar / 21 PSI	B04	1/4" BSPP (only SPG 063)
(-1)00003	(-1) - 3 bar / 42 PSI	B08	1/2" BSPP (only SPG 100)
00010	0 - 10 bar / 145 PSI	N04	1/4" NPT (only SPG 063)
00016	0 - 16 bar / 230 PSI	N08	1/2" NPT (only SPG 100)
00025	0 - 25 bar / 360 PSI	Note: Other thread types on request	
00040	0 - 40 bar / 580 PSI	Adaption	
00060	0 - 60 bar / 850 PSI	S	Stem mounting
00100	0 - 100 bar / 1450 PSI	P	Panel mounting
00160	0 - 160 bar / 2300 PSI	Style of scales	
00250	0 - 250 bar / 3600 PSI	01	BAR / PSI (BAR outside / PSI inside - Standard)
00400	0 - 400 bar / 5800 PSI	02	BAR
00600	0 - 600 bar / 8500 PSI	03	PSI
00680	0 - 680 bar / 10000 PSI	05	PSI / BAR (PSI outside / BAR inside)
00700	0 - 700 bar / 10000 PSI	10	KPa / PSI (KPa outside / PSI inside)
01000	0 - 1000 bar / 14500 PSI	Note: Other scale types on request	

Note: Other pressure ranges on request
Information always refers to the pressure setting of the outside scale.



Area of Application:

protection against pressure gauge overload (single station) or 6 position pressure measurement (multi station)

Characteristics:

- suitable for hydraulic fluids
- max operating pressure: 400 bar
- connection thread size: G 1/4; 1/4 NPT for single station valves on request
- temperature range: 100°C max
- complete with operation manual (plate mounted to the product)

Please consult our office before you use SWS with other fluids.

Dimensions SWS-B04-S1

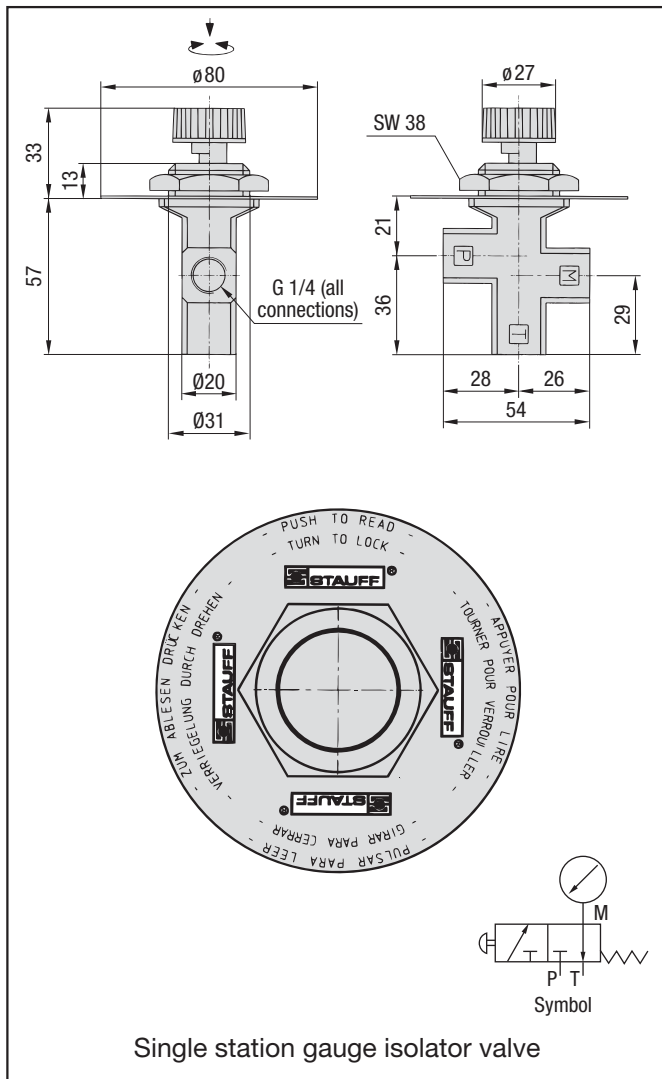

Dimensions SWS-B04-M

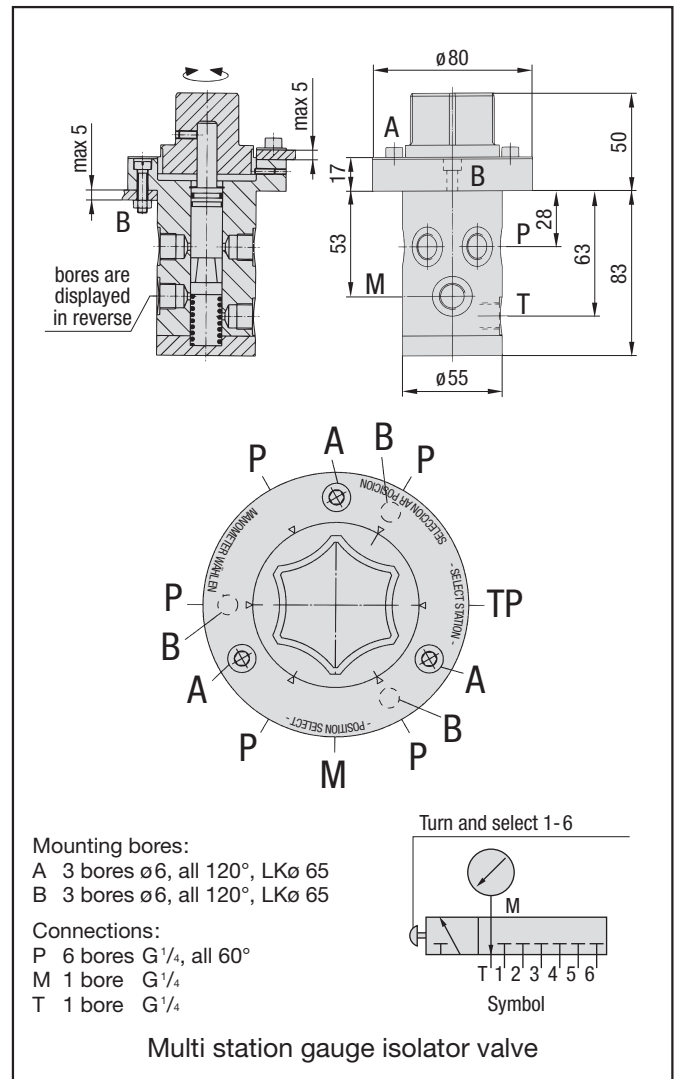

Ordering Code

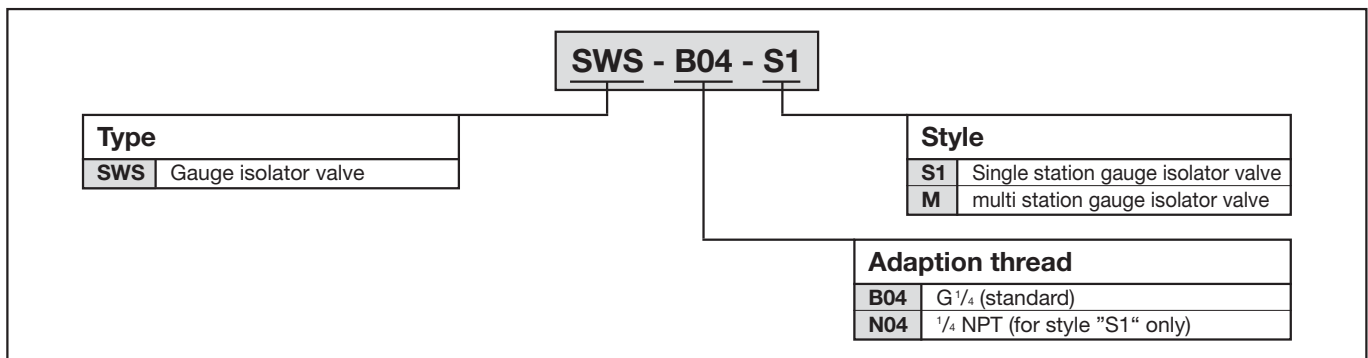



Area of Application:

Tubular support and seal for tank entry return lines (ODs from 6 mm up to 42 mm)

Characteristics:

- vibration damping and sound absorbing
- resistant against oil and solvents
- available in Santoprene or Polypropylene
- A positive bulkhead installation is ensured by a special lip seal.

A remarkable feature of return line bushes is easy installation and they offer assembly costs compared to fittings.

Dimensions

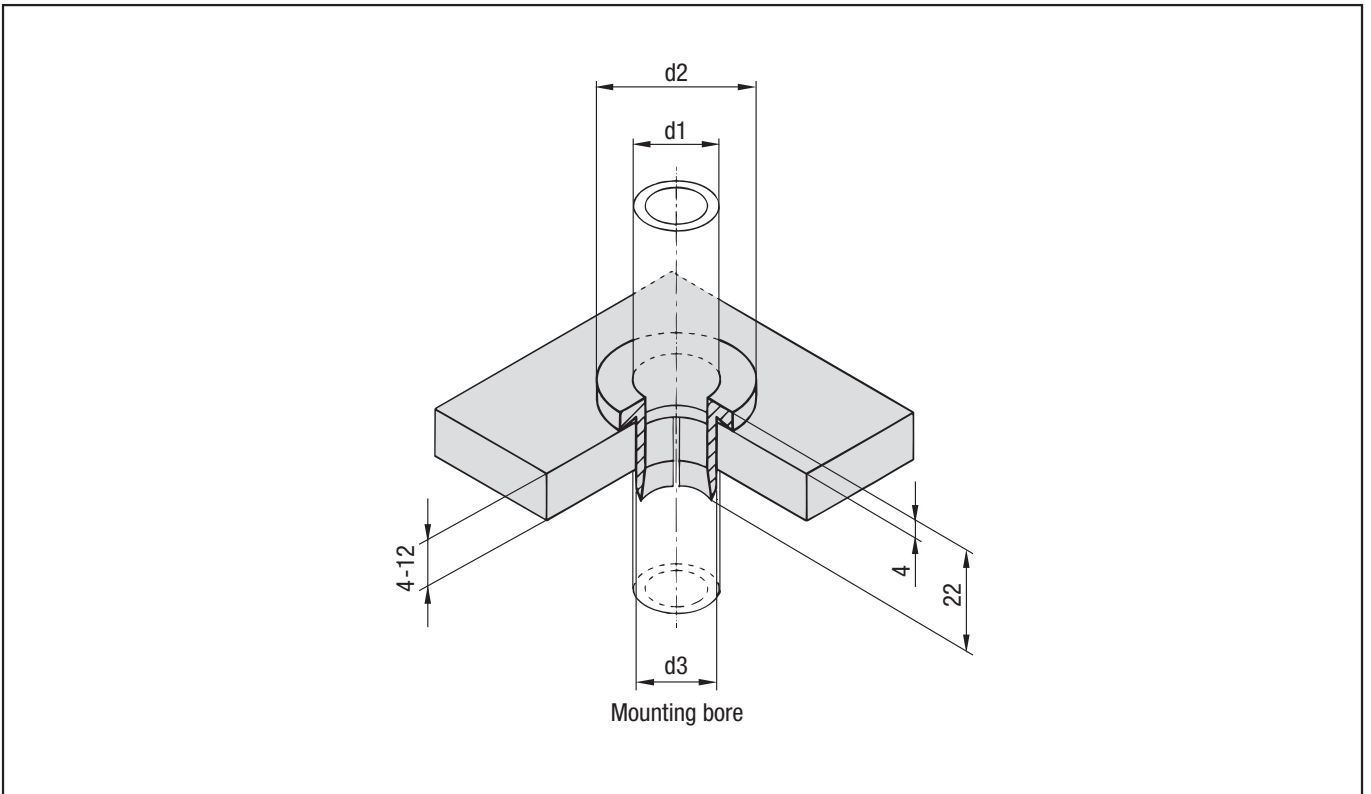

Dimensional Table

Pipe Ø d1	06	08	10	12	14	15	16	18	20	22	25	28	30	35	38	42
d2	18	20	22	24	26	28	28	30	32	34	38	41	43	48	51	55
d3	10	12	14	16	18	20	20	22	24	26	30	33	35	40	43	47

Ordering Code

SRF - xx - xx

<p>Pipe Ø d1</p> <p>see dimensional table</p>		<p>Material</p> <table border="1" style="width: 100%; border-collapse: collapse;"> <tr> <td style="width: 20px;">PP</td> <td>Polypropylene</td> </tr> <tr> <td>SA</td> <td>Santoprene</td> </tr> </table>	PP	Polypropylene	SA	Santoprene
PP	Polypropylene					
SA	Santoprene					